

# LASVIT COLLECTIONS REFLECTIONS





# LASVIT COLLECTIONS

Artistry, craftsmanship  
and Czech glassmaking  
tradition associated with the  
inventiveness and creativity  
of respected international  
designers. Light and the  
beauty of glass. Emotions  
and skills. Such are the  
Lasvit Collections

# LASVIT

Láska — Love / Svit — Light

**Lasvit represents Czech  
glassmaking artistry and tradition  
through collections designed by  
internationally renowned designers  
and crafted by Czech glassmakers.**

# OUR MISSION IS TO TRANSFORM GLASS INTO BREATHTAKING LIGHT AND DESIGN EXPERIENCES

Beauty and elegance came together in the heart of Europe and made Czech glass (also known as Bohemian) famous for its unique and extraordinary quality. It became the decoration of choice in nearly every palace over the centuries. Whether cut, blown or otherwise embellished, the eyes of Roman Emperor Rudolf II, French king Louis XV and Empress Elizabeth the Great of Russia surely fell on its sparkling surface as they shaped human history.

The intelligent manufacture of locally available natural resources and versatility of the product enabled glass to become a staple of Czech heritage, a symbol of the small country's aesthetic tradition and a craft passed on from generation to generation. Bohemian glass adapted to every artistic endeavor and became a small taste of luxury that everybody desires to own to this day.

The Lasvit brand, founded in 2007 by Leon Jakimič, sheds a new light on Bohemian glass and takes it into the next millennium. Lasvit combines the authenticity of glass with innovative technologies and creative craftsmanship. In a few short years, Lasvit established itself as the authority delivering bespoke lighting sculptures and art installations made from hand-blown glass. Collaborations with renowned designers and artists also produced unique glass collections: Nendo, Ross Lovegrove, Daniel Libeskind, Maarten Baas, Czech legends René Roubíček and Bořek Šípek are among those who chose Lasvit to embody their unconventional artistic vision, endow it with the precision and mastery of our glassmakers, producing an impressive creative oeuvre. This epitomizes Lasvit's uncompromising mission: To transform glass into breathtaking light and design experiences.

# LASVIT COLL ECT IONS

Introduction /	10
Design Lighting /	12
Lighting Sculptures /	76
Limited Editions /	132
Designers /	152
Contacts /	154

This chateau was chosen for a photo shoot specifically for its unique atmosphere, which combines splendor and decline. Its atmosphere created the perfect spiritual and aesthetic environment within which to contrast to our current collections. We are pleased to have the possibility, at least symbolically, contribute to its rescue by renting this unique location.

Týnec Chateau was built in the beginning of the 18th century and, in the spirit of Baroque landscaping, lies on the brow of a hill as a prominent landmark. Its architectural heritage, in consummate Baroque style, is among the most valued in the Czech Republic. The fusion of architecture with the landscape (a Baroque trademark) is taken to the maximum here as the chateau spans its entrance drive. Along with its park and several adjacent historical buildings, an enclosed area is created. The architect of the chateau, unknown but confirmed in 2002, was the renowned Giovanni Battista Alliprandi. This is among his largest and most important constructions; another includes the Lobkovic Palace (presently the German Embassy in Prague). We can observe the origins and existence of such a chateau in a Šumava foothills village as a materialization of the dreams of a mad Baroque cavalier.



# LASVIT DESIGN LIGHTING



# CRYSTAL ROCK / BY ARIK LEVY

Certainly not from the Stone Age but closer to the fictional Kryptonite, Crystal Rock appears in the cave of the future as an ambassador to the fusion of nature and man, light and reflection, transparency and mass. All these characteristics are gathered within a perfectly cut, yet roughly sculpted contemporary silex that interacts between light and darkness, suspended in air like a frozen shooting star. It's as if the world stood still the moment you gaze upon it, its multiple reflections and deflections fascinating during the day and even more dynamic at night, when lighted. Crystal Rock's LED source highlights the artistic glassmaking process and advanced gluing techniques, gleaming on its inner curved surfaces and defining form on cut facets.

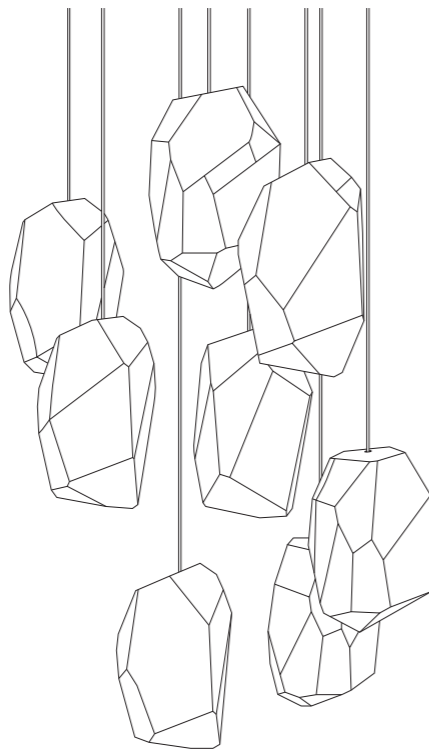

## Crystal Rock

14X031-00	Crystal Rock 1	Dia 130 x H 185 mm / Dia 5,12" x H 7,28"	amber
14X031-01	Crystal Rock 1	Dia 130 x H 185 mm / Dia 5,12" x H 7,28"	blue
14X031-02	Crystal Rock 1	Dia 130 x H 185 mm / Dia 5,12" x H 7,28"	clear
14X031-03	Crystal Rock 1	Dia 130 x H 185 mm / Dia 5,12" x H 7,28"	opal
14X031-04	Crystal Rock 1	Dia 130 x H 185 mm / Dia 5,12" x H 7,28"	red
14X036-00	Crystal Rock 3	Dia 281 x H 180 mm + L / Dia 11,06" x H 7,09" + L	clear / opal / amber
14X036-00	Crystal Rock 3	Dia 281 x H 180 mm + L / Dia 11,06" x H 7,09" + L	clear / opal / red
14X036-00	Crystal Rock 3	Dia 281 x H 180 mm + L / Dia 11,06" x H 7,09" + L	clear / opal / blue
14X037-00	Crystal Rock 5	Dia 364 x H 180 mm + L / Dia 14,33" x H 7,09"	clear / opal / amber / red / blue





# MOULDS / BY JAN PLECHÁČ & HENRY WIELGUS

Moulds is a collection of suspended lights, showcasing Czech crystal at its most resilient and lively form. The series captures a specific moment when molten glass resists its expected shape and freely escapes from the mould as a random, amorphous bubble. The energizing effect of this series arises from the contrast of materials, using the traditional craft techniques of blowing crystal glass into a beech form. The Moulds collection brings powerful emotions into an interior. The composition of varied 'overblown' shapes creates a particularly striking visual effect. Integrated LED light sources were set directly within the charred form, creating an impression that the heat and energy of the glassmaker's kiln remained inside, in historic reference to the art of Czech glassmakers.

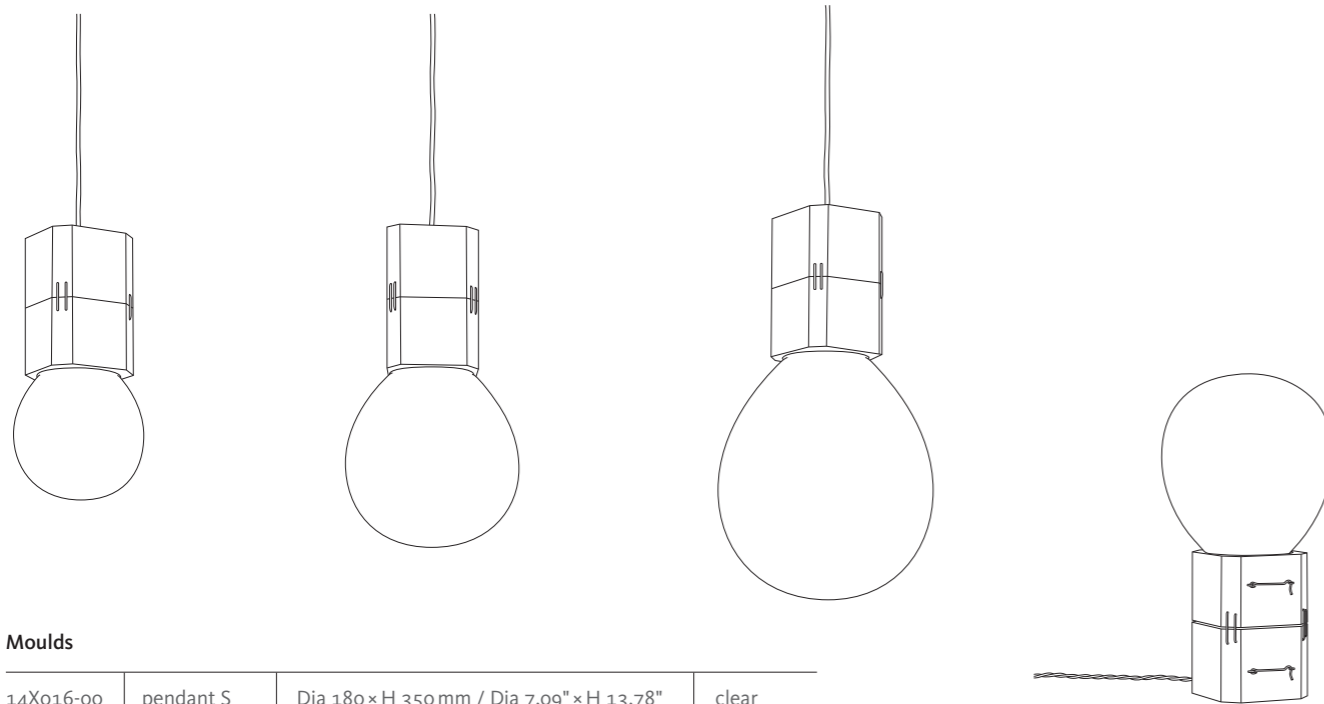

## Moulds

14X016-00	pendant S	Dia 180 x H 350 mm / Dia 7,09" x H 13,78"	clear
14X016-01	pendant S	Dia 180 x H 350 mm / Dia 7,09" x H 13,78"	light amber
14X016-02	pendant S	Dia 180 x H 350 mm / Dia 7,09" x H 13,78"	blue smoke
14X017-00	pendant M	Dia 230 x H 420 mm / Dia 9,06" x H 16,54"	clear
14X017-01	pendant M	Dia 230 x H 420 mm / Dia 9,06" x H 16,54"	light amber
14X017-02	pendant M	Dia 230 x H 420 mm / Dia 9,06" x H 16,54"	blue smoke
14X018-00	pendant L	Dia 290 x H 520 mm / Dia 11,42" x H 20,47"	clear
14X018-01	pendant L	Dia 290 x H 520 mm / Dia 11,42" x H 20,47"	light amber
14X018-02	pendant L	Dia 290 x H 520 mm / Dia 11,42" x H 20,47"	blue smoke
14X061-00	table lamp M	Dia 230 x H 420 mm / Dia 9,06" x H 16,54"	clear
14X061-01	table lamp M	Dia 230 x H 420 mm / Dia 9,06" x H 16,54"	blue smoke
14X061-02	table lamp M	Dia 230 x H 420 mm / Dia 9,06" x H 16,54"	amber
14X062-00	table lamp L	Dia 286 x H 520 mm / Dia 11,26" x H 20,47"	clear
14X062-01	table lamp L	Dia 286 x H 520 mm / Dia 11,26" x H 20,47"	blue smoke
14X062-02	table lamp L	Dia 286 x H 520 mm / Dia 11,26" x H 20,47"	amber





# SPIN LIGHT / BY LUCIE KOLDOVÁ

Spin light's dynamic expression is based on a simple rotational form, resembling a child's spinning top or the silhouette of whirling dervishes. Clear transparent lamps with colored metal tops feature in its minimal graphical character, finished in various materials and colors.

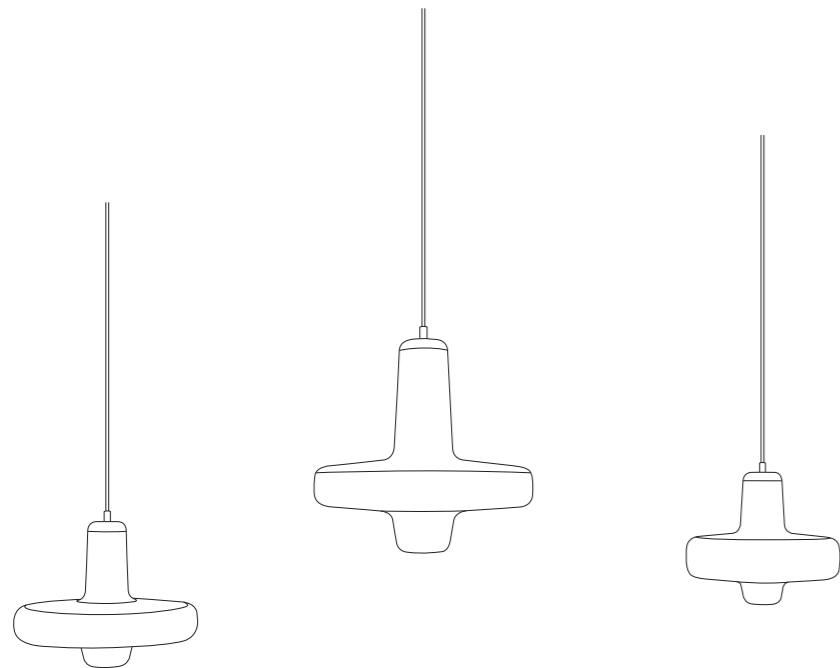

## Spin Light

14X001-00	S	Dia 330 x H 305 mm / Dia 12,99" x H 12,01"	black matt / clear
14X001-01	S	Dia 330 x H 305 mm / Dia 12,99" x H 12,01"	white glossy / clear
14X001-02	S	Dia 330 x H 305 mm / Dia 12,99" x H 12,01"	nickel plated / clear
14X001-03	S	Dia 330 x H 305 mm / Dia 12,99" x H 12,01"	polished brass / clear
14X001-04	S	Dia 330 x H 305 mm / Dia 12,99" x H 12,01"	cooper red plated / clear
14X002-00	M	Dia 380 x H 330 mm / Dia 14,96" x H 12,99"	black matt / clear
14X002-01	M	Dia 380 x H 330 mm / Dia 14,96" x H 12,99"	white glossy / clear
14X002-02	M	Dia 380 x H 330 mm / Dia 14,96" x H 12,99"	nickel plated / clear
14X002-03	M	Dia 380 x H 330 mm / Dia 14,96" x H 12,99"	polished brass / clear
14X002-04	M	Dia 380 x H 330 mm / Dia 14,96" x H 12,99"	cooper red plated / clear
14X003-00	L	Dia 430 x H 420 mm / Dia 16,93" x H 16,54"	black matt / clear
14X003-01	L	Dia 430 x H 420 mm / Dia 16,93" x H 16,54"	white glossy / clear
14X003-02	L	Dia 430 x H 420 mm / Dia 16,93" x H 16,54"	nickel plated / clear
14X003-03	L	Dia 430 x H 420 mm / Dia 16,93" x H 16,54"	polished brass / clear
14X003-04	L	Dia 430 x H 420 mm / Dia 16,93" x H 16,54"	cooper red plated / clear





# FROZEN / BY MAXIM VELČOVSKÝ

The Frozen collection was inspired by the transformation of water into ice. This moment is similar to the work in a glassmaker shop. Creating a solid object from a liquid material is an essential characteristic of glass. Each design attempts this small miracle –turning liquid glass to solid form. Velčovský allows the glass to spill over a metal form and seeks advantage in its natural properties. Each piece traces a unique record of the process, becoming an original. Maxim found inspiration among the shards of ice created by nature and applied that element of natural randomness to his craft in the context of glassmaking. The result is a 'frozen' sculpture, that combines the richness of glass textures, wrinkled details, bubbles and varied thicknesses.

26 / 27

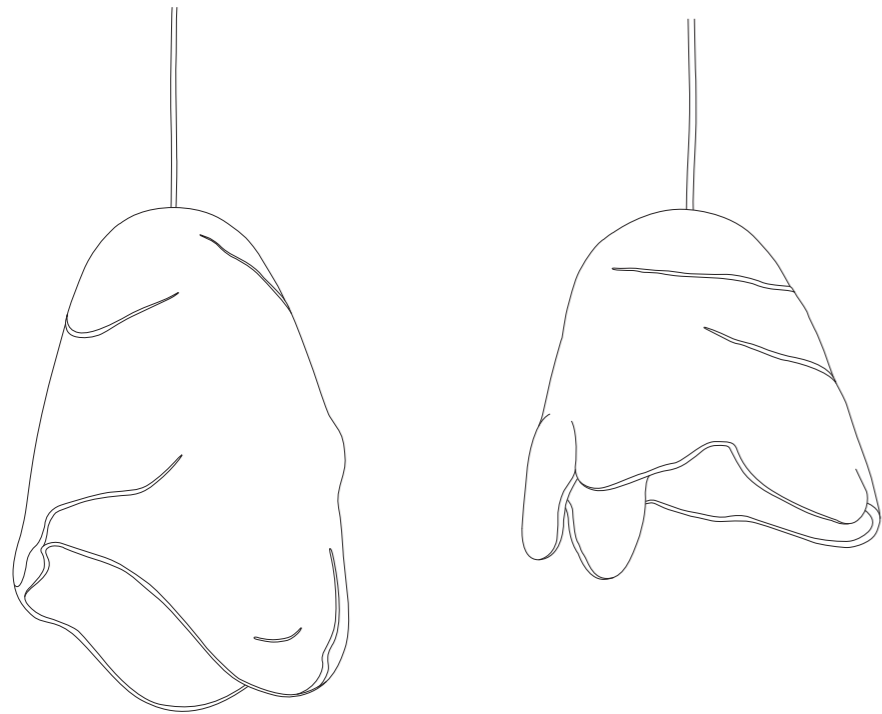

## Frozen

14X014-00	S	Dia 250 x H 250 mm / Dia 9,84" x H 9,84"	clear
14X015-00	L	Dia 290 x H 350 mm / Dia 11,42" x H 13,78"	clear









# BONBON / BY MÁRIA ČULENOVÁ

Bonbon catches your eye with its hand-blown glass shade reminiscent of a candy wrapper, playfully crimped at the top. This elegant cover is supported by a cut-crystal core lighted element in the shape of a hard-candy. The clean shape of Bonbon and superb quality of its execution speaks to Lasvit's dedication to perfection. A reminder of that special moment we unwrap a favorite candy, Bonbon combines a playful theme with an engagingly delicate form.

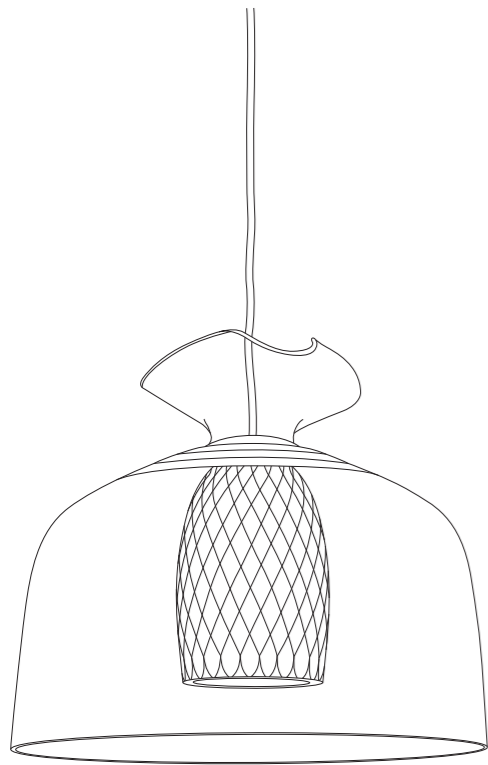

## Bonbon

15X013-00	Dia 460 x H 380 mm + L / Dia 18,11" x H 14,96" + L	cutted smoke glass / clear
15X013-01	Dia 460 x H 380 mm + L / Dia 18,11" x H 14,96" + L	cutted clear glass / clear



# HATS / BY DEFORM

Reminiscent of the late Victorian bowler hat, Hats concept combines the demand for absolute practicality with simplicity of design. Inspired by the industrial lighting and street lamps in European cities, Hats carries a subtle sense of familiarity. Its transparent colored glass topper lights the ceiling while the clear bottom is starkly utilitarian. Hats' sections are connected by three industrial-style custom screws, paying homage to its original inspiration. Inside, a translucent light bulb softens and evenly distributes the light. Hats is the ideal designer-light for even the smallest interiors or a perfect unit to combine into groups.

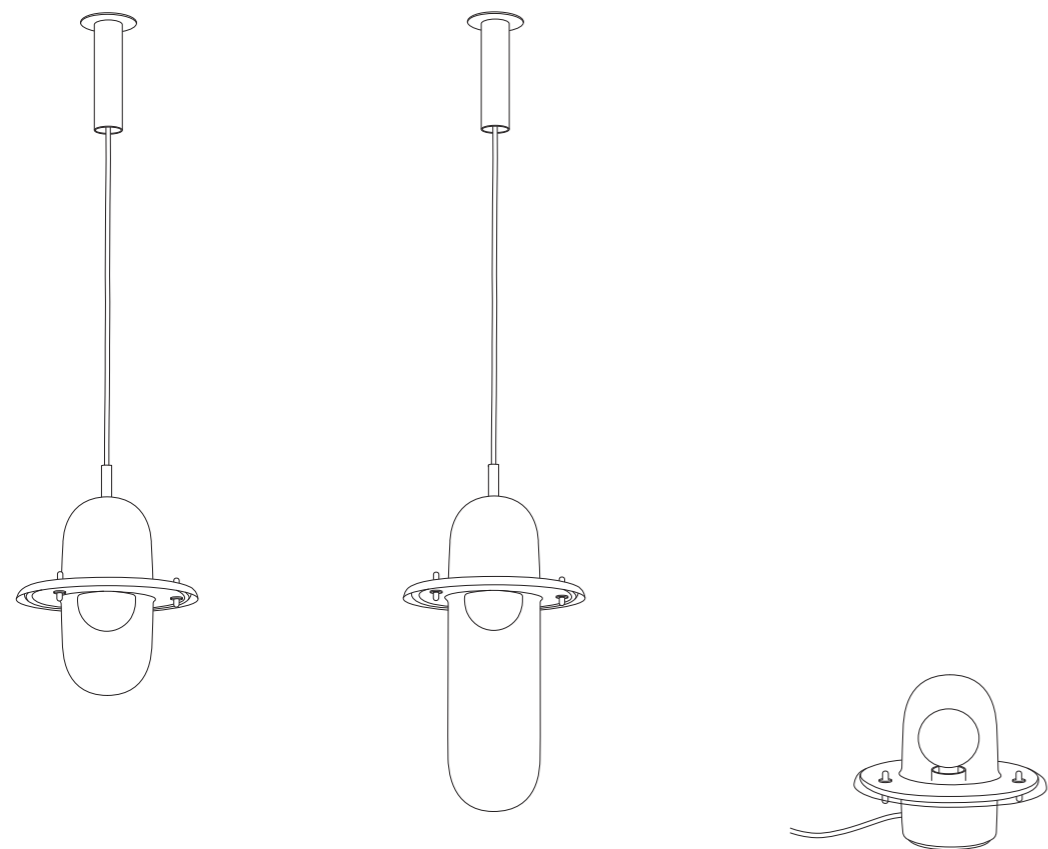

## Hats

15X009-00	M	Dia 250 × H 327 mm + L / Dia 9,84" × H 12,87" + L	clear
15X009-01	M	Dia 250 × H 327 mm + L / Dia 9,84" × H 12,87" + L	opal
15X009-02	M	Dia 250 × H 327 mm + L / Dia 9,84" × H 12,87" + L	black
15X010-00	L	Dia 250 × H 483 mm + L / Dia 9,84" × H 19,02" + L	clear
15X010-01	L	Dia 250 × H 483 mm + L / Dia 9,84" × H 19,02" + L	opal
15X010-02	L	Dia 250 × H 483 mm + L / Dia 9,84" × H 19,02" + L	black
15X011-00	table lamp	Dia 226 × H 250 mm / Dia 8,9" × H 9,84"	clear





# POLYGON / BY JAN PLECHÁČ & HENRY WIELGUS

Polygon expresses light, glass and the glass-cutter's art in perfect harmony. Combining the traditional shape of a hand-blown glass lampshade with the polygonal network often used in 3D modeling programs, Polygon creates a new and unusual décor with two distinct looks. In the daytime, light gently refracts from its matte surface, while at night the interior light source reveals the elegance of the design in full detail.

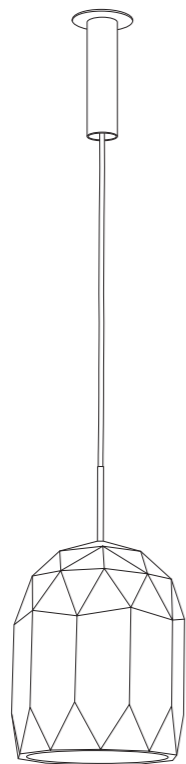

## Polygon

15X008-00	Dia 240 × H 320 mm / Dia 9,45" × 12,6"	clear
15X008-01	Dia 240 × H 320 mm / Dia 9,45" × 12,6"	light amber
15X008-02	Dia 240 × H 320 mm / Dia 9,45" × 12,6"	light smoke
15X008-03	Dia 240 × H 320 mm / Dia 9,45" × 12,6"	light pink
15X008-04	Dia 240 × H 320 mm / Dia 9,45" × 12,6"	light purple





# WELL / BY MEJD STUDIO

Well is light inspired by traditional water wells. It takes the principle of the simple wooden handle mechanism winding of the rope and thus changing its distance or the bulbs depth inside the glass container like the bucket singing into the water. In the case of lower positions, the light becomes gradient blue while, in the second variant, it goes from clear transparent to sanded matte.

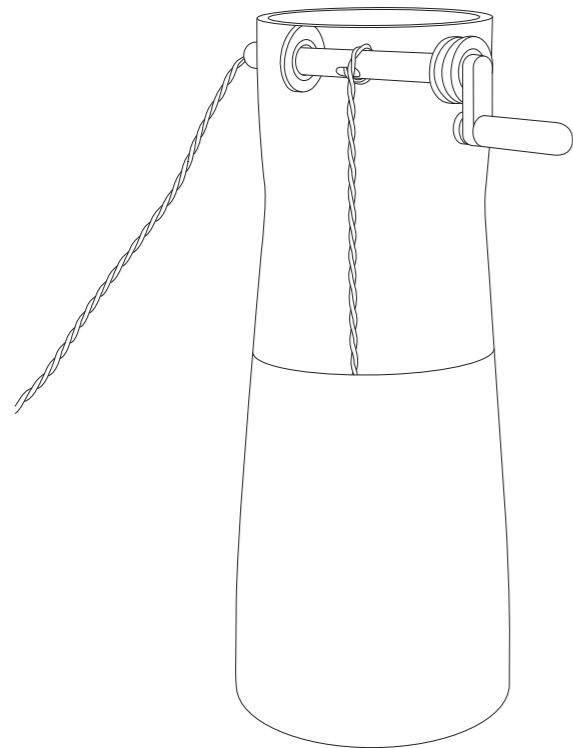

## Well

15X014-00	Dia 200 x H 600 mm / Dia 7,87" x H 23,62"	clear / sandblasted
15X014-01	Dia 200 x H 600 mm / Dia 7,87" x H 23,62"	cobalt / clear





# CLOVER / BY MICHAEL YOUNG

The Clover array is a direct descendent of the Super Clover, a large geometric lighting form based upon extensive study of the opportunities presented by creating light sculptures within mathematical grid systems. Clover extracts specific elements from this study to create simple and small, usable lighting objects that easily find everyday use in the home. Michael Young, through his collaboration with Lasvit, hopes to bring some of his artistic talent into personal residences.

46 / 47

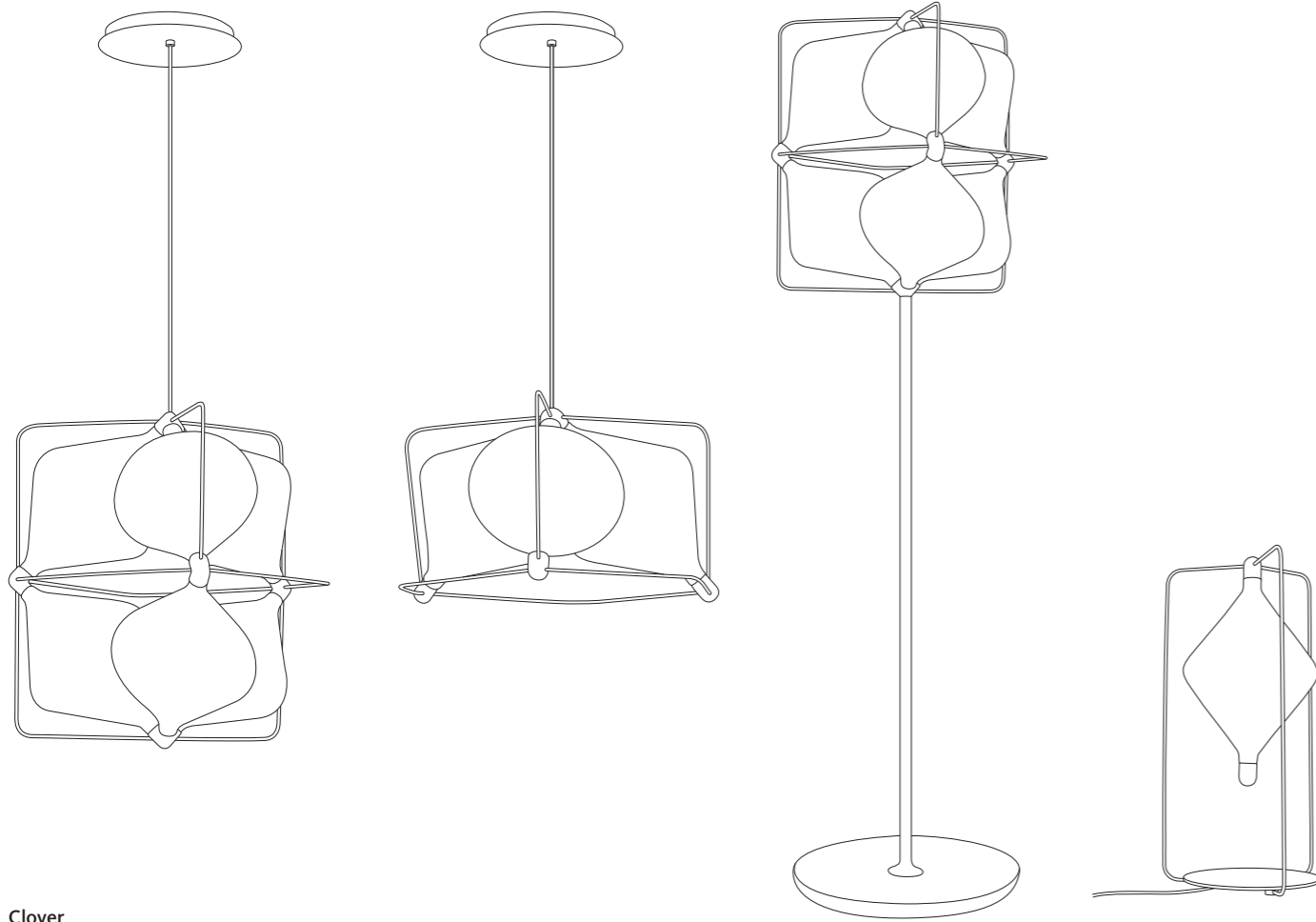

## Clover

14X028-00	3 pendant	Dia 510 x H 270 mm + L / Dia 20,08" x H 10,63" + L
14X029-00	6 pendant	Dia 510 x H 520 mm + L / Dia 20,08" x H 20,47" + L
14X030-00	floor lamp	Dia 510 x H 1630 mm / Dia 20,08" x H 64,17"
14X0051-00	table lamp	Dia 260 x H 550 mm / Dia 10,24" x 21,65"





# NEVERENDING GLORY COLLECTION / BY JAN PLECHÁČ & HENRY WIELGUS

The Neverending Glory collection reflects nostalgic emotions and interprets opulent candle chandeliers in new way to symbolize those prime moments of appreciation and glory. It is possible within individual silhouettes to recognize the iconic chandeliers from five of the world's most eminent concert halls and theaters; La Scala in Milan, Palais Garnier in Paris, the Metropolitan Opera in New York, the Bolshoi Theater in Moscow, as well as the Czech Republic's Estates Theater in Prague.

50 / 51

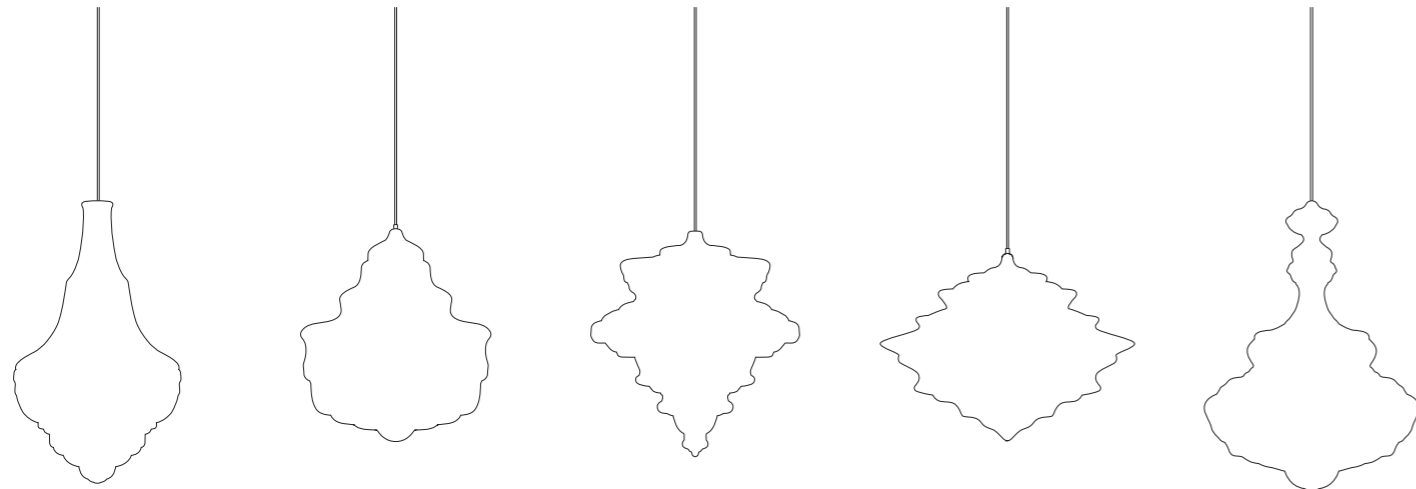

Prague Estate Theatre

Palais Garnier

La Scala

Metropolitan Opera

Bolshoi Theatre

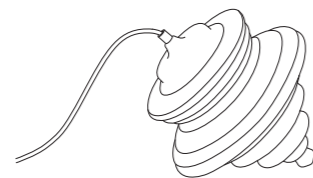

## Neverending Glory Collection

13X008-00	Bolshoi Theatre	Dia 550 × H 780 mm + L / Dia 21,65" × H 30,71" + L	clear / opal / smoke
13X009-00	Metropolitan Opera	Dia 500 × H 410 mm + L / Dia 19,69" × H 16,14" + L	clear / opal / smoke
13X010-00	La Scala	Dia 550 × H 600 mm + L / Dia 21,65" × H 23,62" + L	clear / opal / smoke
13X011-00	Prague Estate Theatre	Dia 440 × H 730 mm + L / Dia 17,32" × H 28,74" + L	clear / opal / smoke
13X012-00	Palais Garnier	Dia 510 × H 555 mm + L / Dia 20,08" × H 21,85" + L	clear / opal / smoke
15X007-00	table lamp	Dia 280 × H 260 mm / Dia 11,02" × H 10,24"	clear





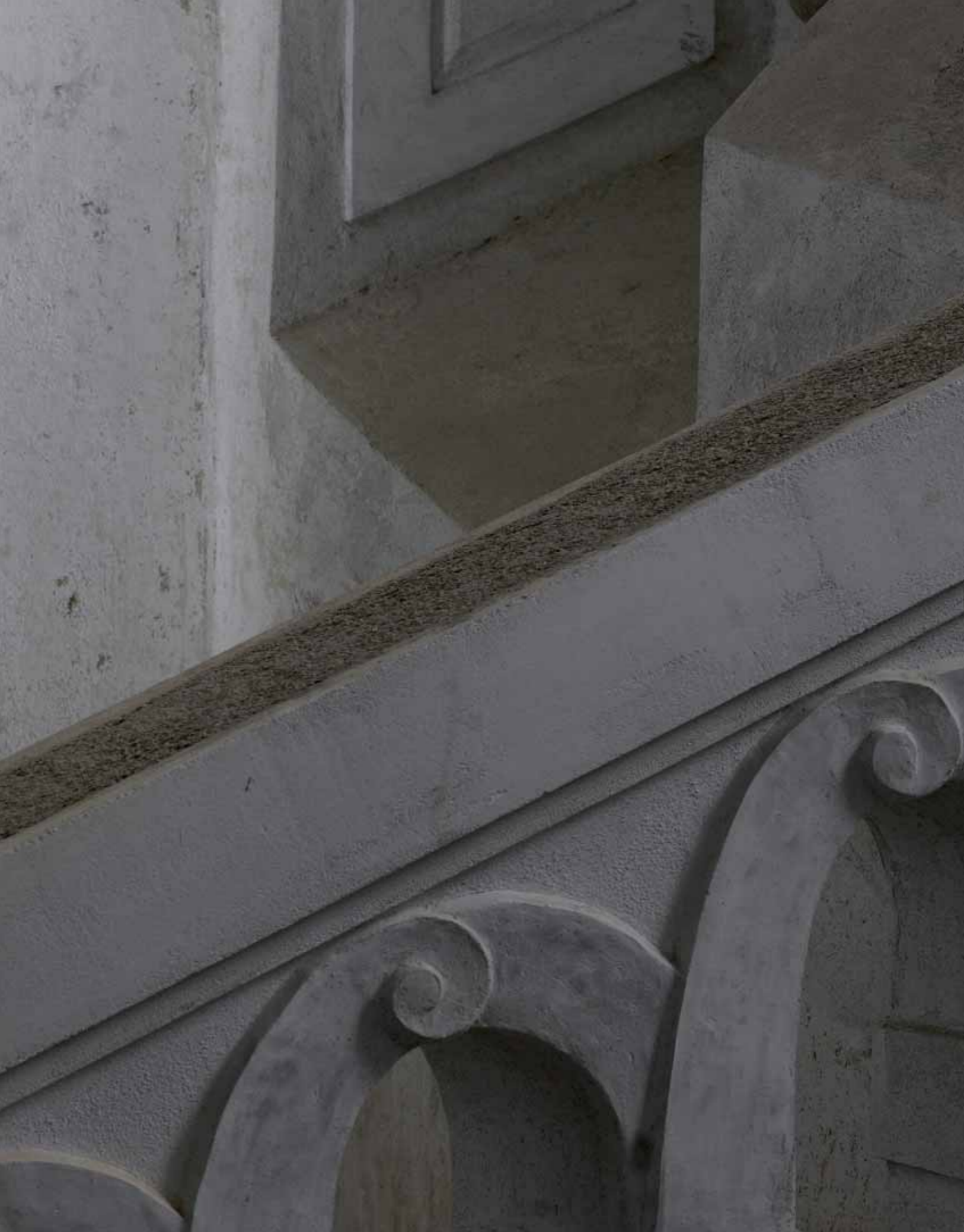

# JAR RGB / BY ARIK LEVY

Jar RGB is a lighting project that weds colorful glass blowing technique to the concept of RGB color-mixing. Using opal glass for one of the hanging jars allows it to turn into a large generative light for the entire fixture. Observing one jar through others and the space surrounding them creates a unique and lasting discovery of color super-imposition.

56 / 57

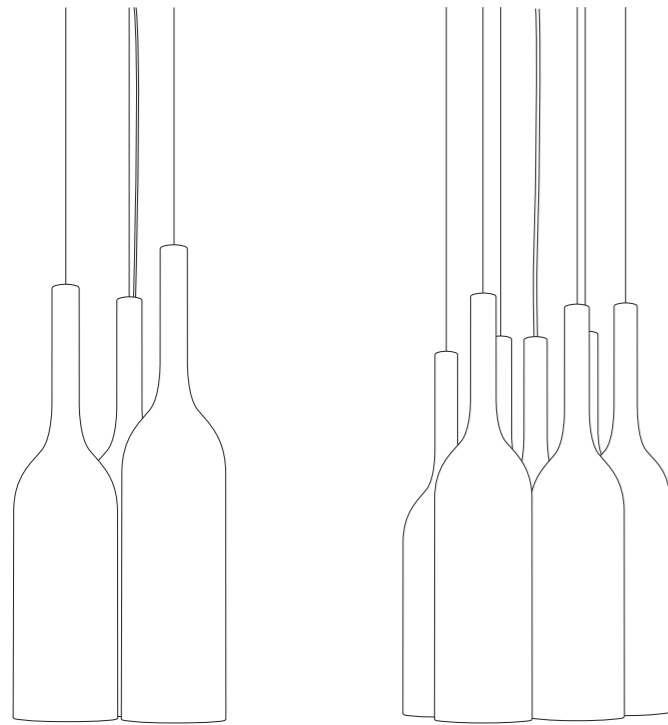

## Jar RGB

13X004-00	Jar 3	Dia 305 x H700 + L max 2000 mm / Dia 12,01" x H 27,56" + L max 78,74"	opal, green, blue
13X004-00	Jar 3	Dia 305 x H700 + L max 2000 mm / Dia 12,01" x H 27,56" + L max 78,74"	opal, green, red
13X004-00	Jar 3	Dia 305 x H700 + L max 2000 mm / Dia 12,01" x H 27,56" + L max 78,74"	opal, red, blue
13X005-00	Jar 7	Dia 465 x H700 + L max 2000 mm / Dia 18,31" x H 27,56" + L max 78,74"	opal, red, green, blue





# PRESS LAMP / BY NENDO

The Press Lamp design is available in two styles: a pendant lamp and a floor lamp. In this design, glass tubes are pressed as though they were pinched and the light source is fitted into the resulting narrowed space. Unusual in that it relies on no metal form, its compression produces a soft, organic form and imbues each lamp with a singular visual aspect.

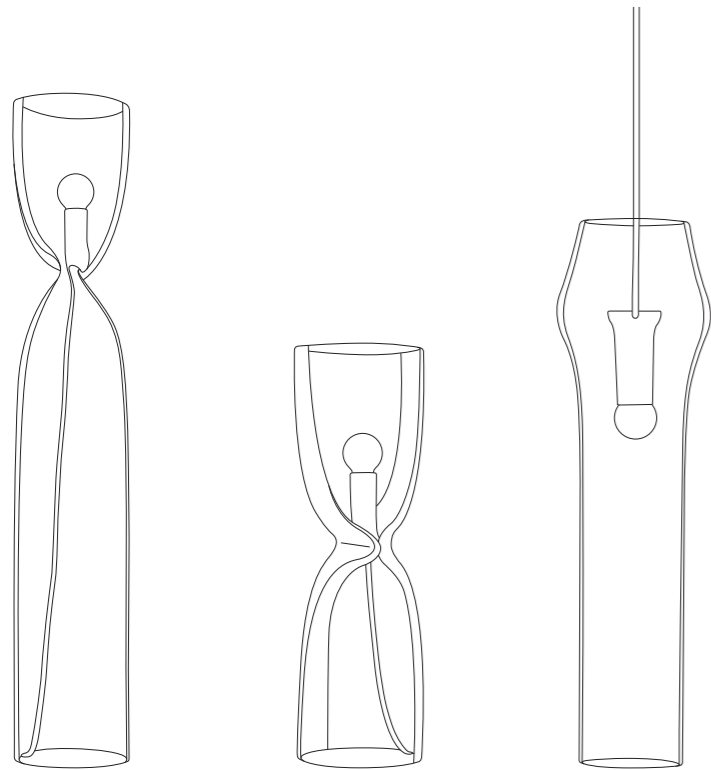

## Press lamp

12X007-00	pendant	Dia 90 × H450 mm / Dia 3,54" × H 17,72"	clear
12X007-01	pendant	Dia 90 × H450 mm / Dia 3,54" × H 17,72"	smoke
12X008-00	floor lamp	Dia 140 × H460 mm / Dia 5,51" × H 18,11"	clear
12X008-01	floor lamp	Dia 140 × H460 mm / Dia 5,51" × H 18,11"	smoke
12X009-00	floor lamp	Dia 140 × H630 mm / Dia 5,51" × H 24,80"	clear
12X009-01	floor lamp	Dia 140 × H630 mm / Dia 5,51" × H 24,80"	smoke







# INHALE LAMP / BY NENDO

The Inhale Lamp is formed by blowing glass into the form of an air bubble and then quickly sucking the air away. Ordinarily, glass is made by blowing air continually into molten material. The Inhale Lamp, on the other hand, is created by the act of inhaling. It's a form produced by negative air pressure.

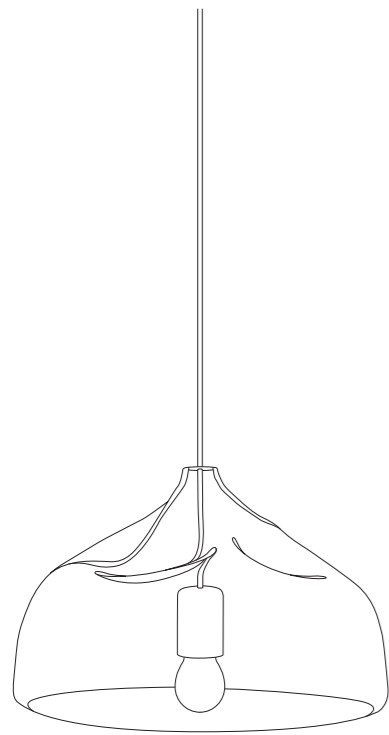

## Inhale lamp

12X004-00	Dia 410 (approx) × H315 mm / Dia 16,14" × H 12,40"	clear
12X004-02	Dia 410 (approx) × H315 mm / Dia 16,14" × H 12,40"	opal





# HYDROGENE / BY LARS KEMPER AND PETER OLAH

Hydrogene is a highly versatile architectural system of illuminated glass pieces. Combinable, artistic elements in various shapes create a wide range of possibilities for use in interior decoration as well as lighting design. Symbolic of the movement of liquid, air bubbles in water, and the fluidity of glass, this design delivers sufficient light with a modish style. Hydrogene brings together an architectural arrangement of light elements with a special bubbly texture that is illuminated by a series of LEDs reflecting in the adjacent mirror components. The textured, luminous surface of these unique, contemporary fittings creates a playful show of light that boasts an incredible depth of radiance.

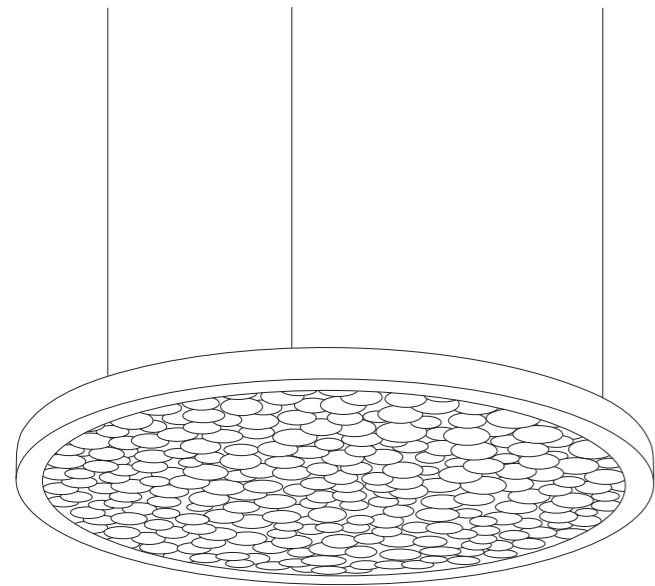

## Hydrogene

11X001-00	Dia 750 mm / Dia 29,53"	clear
11X001-01	Dia 500 mm / Dia 19,69"	clear
11X001-02	Dia 380 mm / Dia 14,96"	clear





# GLITTERS / BY GABRIELA NÁHLÍKOVÁ

These provocatively ice clear “pleated” lamp-shades, their right angle cranked legs standing in contrast with their ornamental composition, cast shadows that appear on the walls after switching on the light. The classical design, along with its optical projection merges into an unexpected form of “romantic functionalism”. Shadows are created virtually all around, but only those thrown by the Glitters collection are able to so definitively enhance a space, both day and night. Light, the translucent texture of the glass and its striking expressiveness call forth memories as well as enhance beauty of a room to make it real; more real, as shadows always reveal more than light itself.

72 / 73

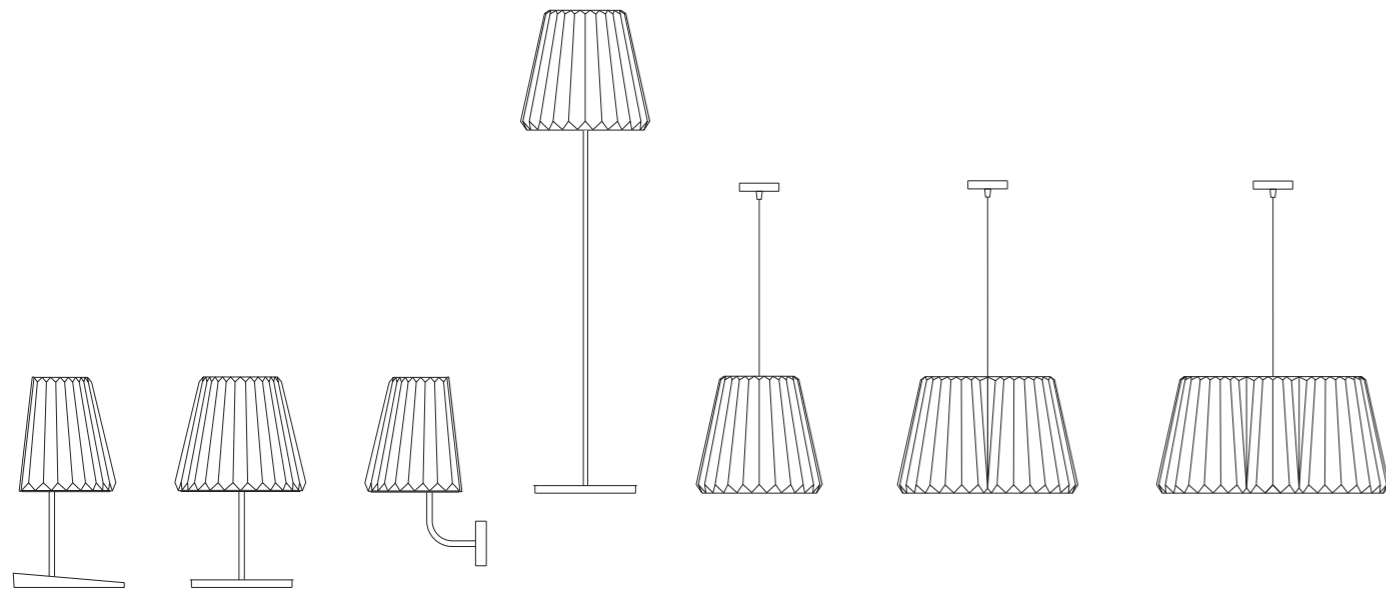

## Glitters

07G090-00A	table lamp half	L 230 × W 200 × H 210 × OH 390 mm / L 9,06" × W 7,87" × H 8,27" × OH 15,35"
07G090-00B	table lamp	Dia 310 × H 210 × OH 390 mm / Dia 12,20" × H 8,27" × OH 15,35"
10G005-00	floor lamp	Dia 310 × H 1400 mm / Dia 12,20" × H 55,12"
07G090-05	pendant 1	Dia 320 × H 300 × OH 805 mm / Dia 12,60" × H 11,81" × OH 31,69"
10G007-00	pendant 2	L 515 × W 320 × H 300 × OH 805 mm / L 20,28" × W 12,60" × H 11,81" × OH 31,69"
10G004-00	pendant 3	L 700 × W 320 × H 300 × OH 840 mm / L 27,56" × W 12,60" × H 11,81" × OH 33,07"
07G090-01	wall sconce	L 230 × H 210 × OH 390 × projection 220 mm / L 9,06" × H 8,27" × OH 15,35" × P 8,66"





# LASVIT LIGHTING SCULPTURES



# DAS POP / BY MAARTEN BAAS

With the 'Das Pop' chandelier, Maarten Baas looks to classic, recognizable shapes, yet with a modern and almost comic twist. Technically, it's a unique joint-venture between two crafts, the classic hand-blown glass by Lasvit and the clay-covered arms by Baas, along with his production team from Den Herder Production House. Emphasizing random shapes, Das Pop combines the personal and non-industrial feel of the product. Modular components of the chandelier provide an opportunity to create variations within its fixed structure.

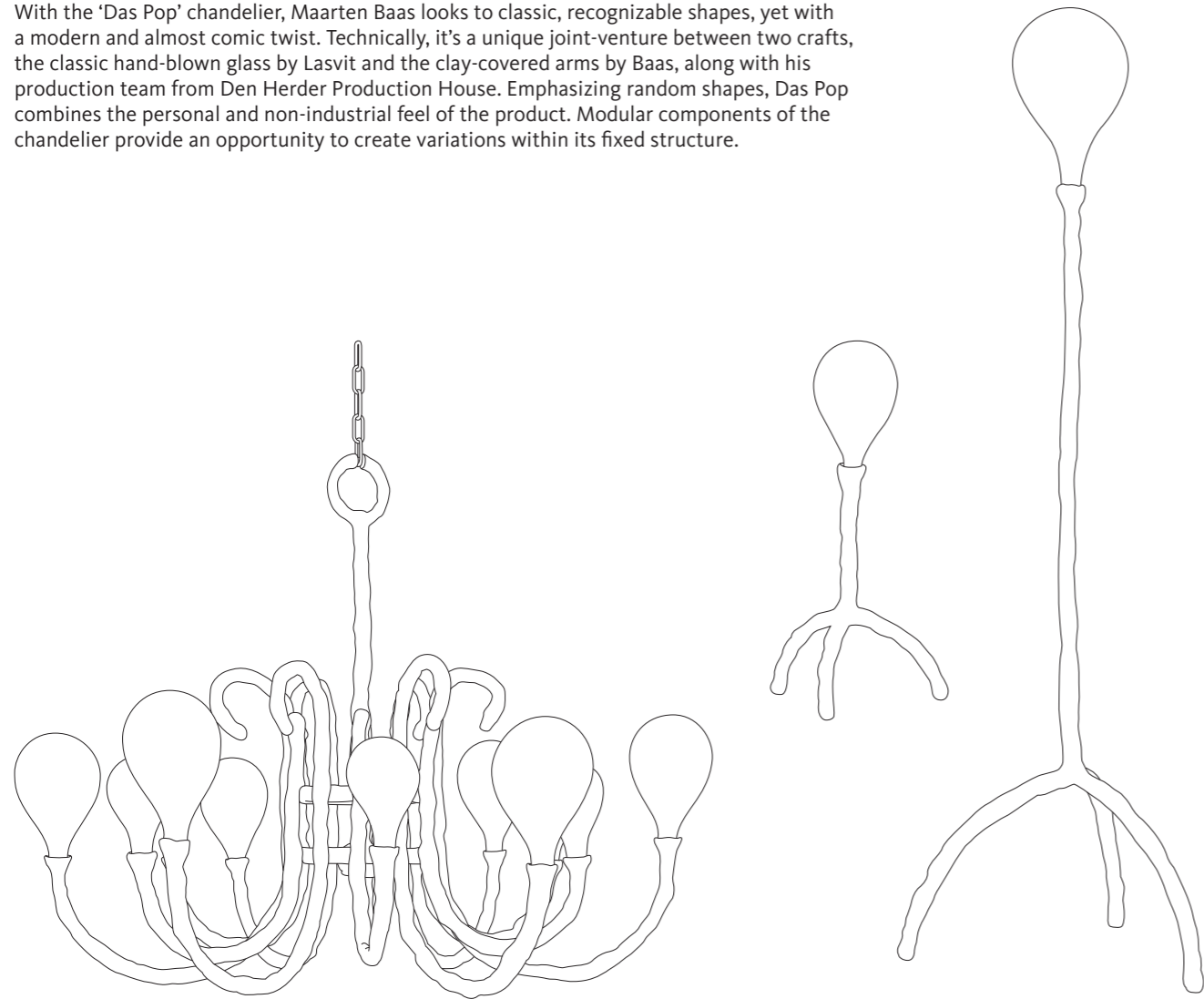

## Das Pop

14X038-00	Das Pop chandelier / 1 level	Dia 1200 × H 800 mm + L / Dia 47,24" × 31,5" + L	opal
14X039-00	Das Pop floor lamp	Dia 600 × H 1850 mm / Dia 23,62" × H 72,83"	opal
14X040-00	Das Pop table lamp	Dia 350 × H 650 mm / Dia 13,78" × H 25,59"	opal





# DAS POP LIGHT / BY MAARTEN BAAS

With this piece Maarten Baas looked toward classic, recognizable shapes, yet with a modern and almost comic twist. Technically it's a unique joint-venture between the classic hand-blown glass by Lasvit and the clay-covered arms by Baas and his production team from Den Herder Production House.

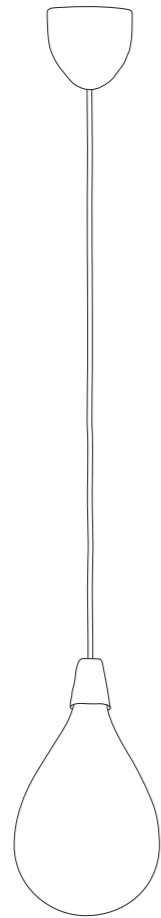

## Das Pop Light

15X012-00 | Dia 175 x H 310 mm + L mm / Dia 6,89" x H 12,2" + L | opal



# FUNGO CHANDELIER / BY CAMPANA BROTHERS

The Fungo chandelier was inspired by the fascinating shape of a mushroom growing on wood. Yet this mushroom didn't grow in the forest, but was discovered in the basement of Lasvit's glassworks, where an ancient wooden glassblowing mold had succumbed to the ravages of humidity. The Campana brothers chose to blend this newfound accidental theme with Lasvit's glassmaking tradition and fuse their techniques with natural materials. The resulting artwork displays a striking contrast between the formal rigidity of the chandelier's wooden structure and the blown-glass that appears to emerge spontaneously from the wood.

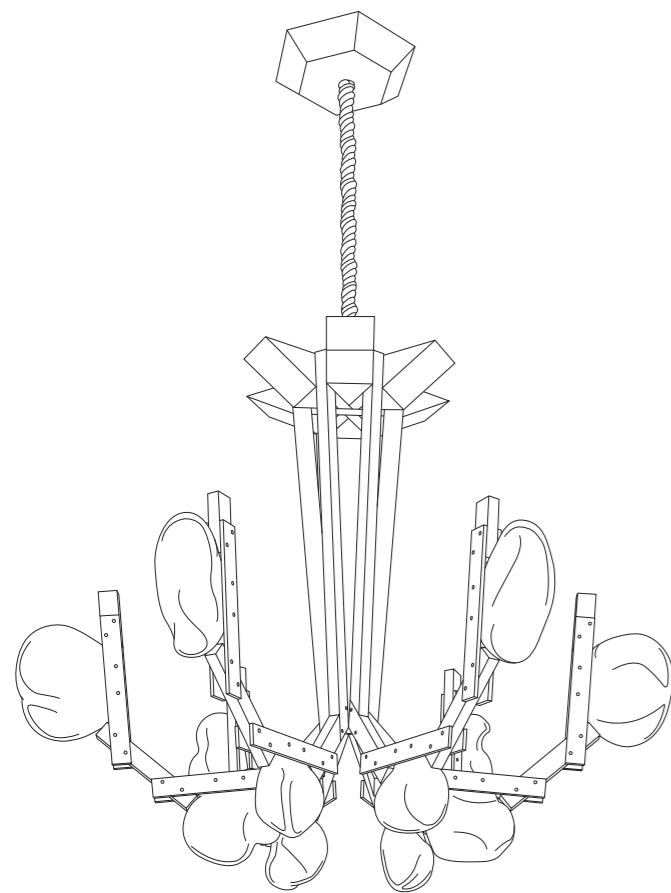

## Fungo

15X004-00 | Dia 1700×H 1250mm + L / Dia 66,93"×49,21" + L | clear / wood





# CANDY COLLECTION / BY CAMPANA BROTHERS

The Candy collection builds on the colorful universe of the Campana Brothers' Sushi series, but explores and expresses it through glass, a material that has fascinated them since childhood. They found inspiration for this collection in the colorful candies sold in popular markets in Brazil. This initial concept was enthusiastically received by Czech glass-masters, always ready to explore new techniques and visions. The Candy Collection includes Sphere chandelier, Ring chandelier and Lollipop table lamp, all conceived and produced in hand-blown glass and metal.

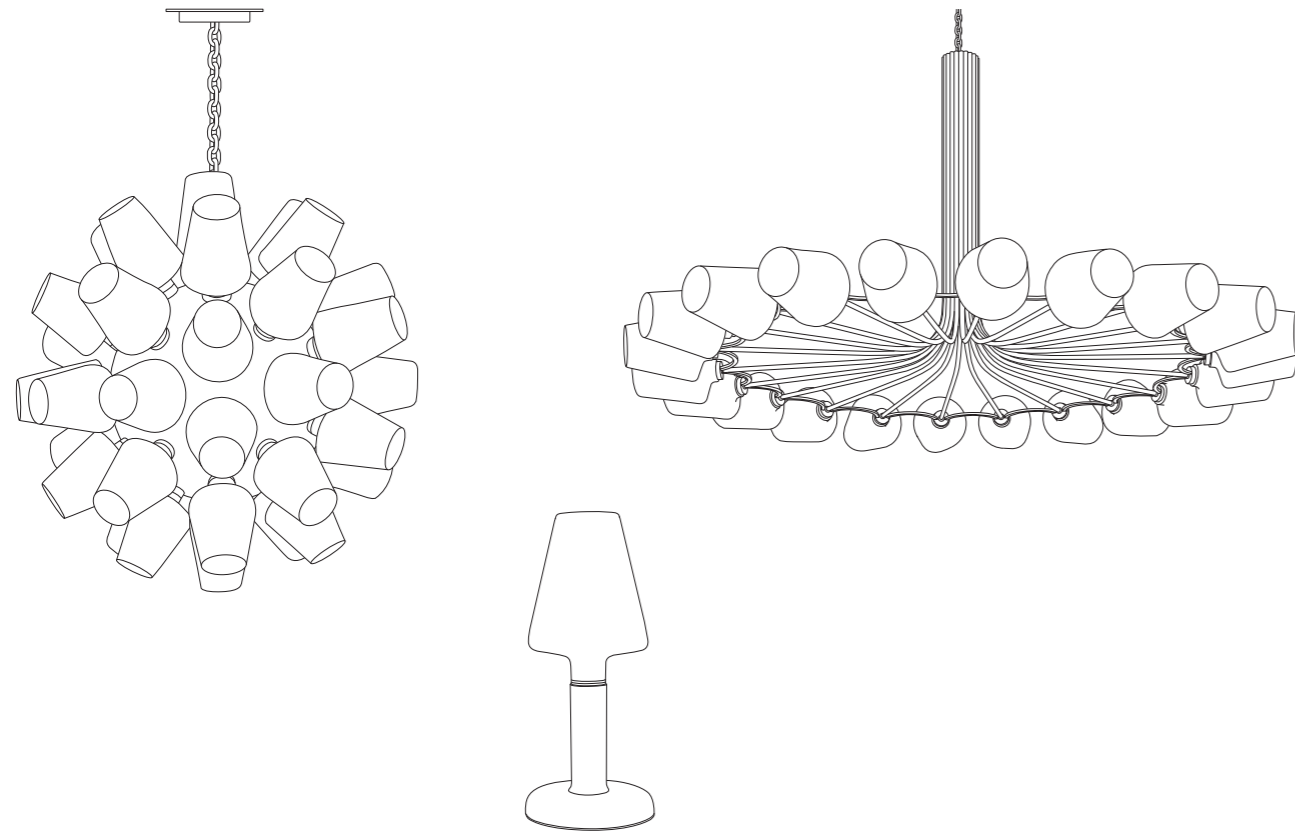

## Candy Collection

15X006-01	Ring	Dia 1500 x H 800mm + L / Dia 59,06" x H 31,5" + L	color / opal
15X014-01	Sphere	Dia 830 mm + L / Dia 32,68" x L	color / opal
14X006-00	Lollipop table lamp	Dia 175 x H 410 mm / Dia 6,89" x H 16,14"	color / opal









# TRANSMISSION / BY DEFORM

Lasvit Transmission by studio deFORM is a unique lighting sculpture based on experimentation with Simax borosilicate glass and produced in cooperation with Kavalierglass. Lasvit Transmission is cut and welded into an original composition that offers unpredictable and surprising lumino-kinetic effects from every angle. Glass parts are joined by heat, creating individual elements that become one material and one body.

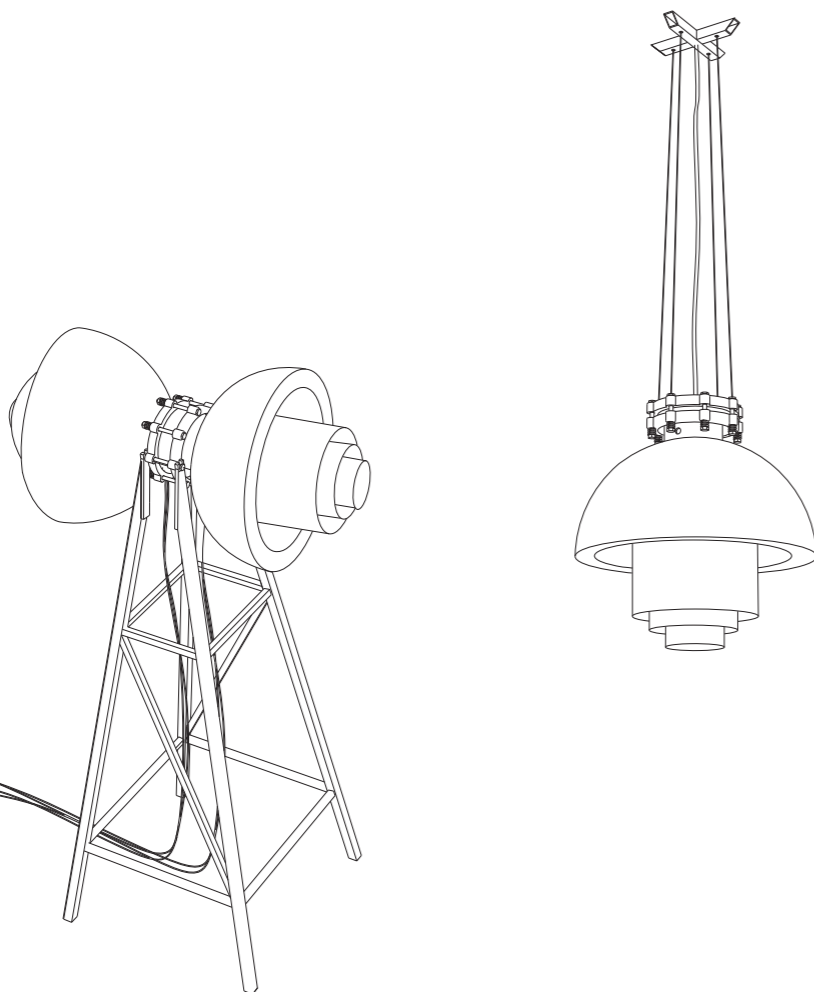

## Transmission

14X047-00	Transmission floor lamp	H 2000 x W1200 x D 700 mm / H 78,74" x W47,24" x D 27,56"	clear / Simax
14X046-00	Transmission pendant	Dia 610 x H 610 mm + L / H 24,02" x W 24,02" x D 24,02"	clear / Simax





# PRATO DI FIORI / BY BOŘEK ŠÍPEK

The unconventional Prato Di Fiori chandelier is inspired by a mountain meadow in bloom, with randomly scattered flowers of various colors. Nevertheless, the piece is harmonious as a whole. It is produced with hand-blown components decorated with optic moulds in varied shapes. The multiple mixed shapes and colors brighten every interior.

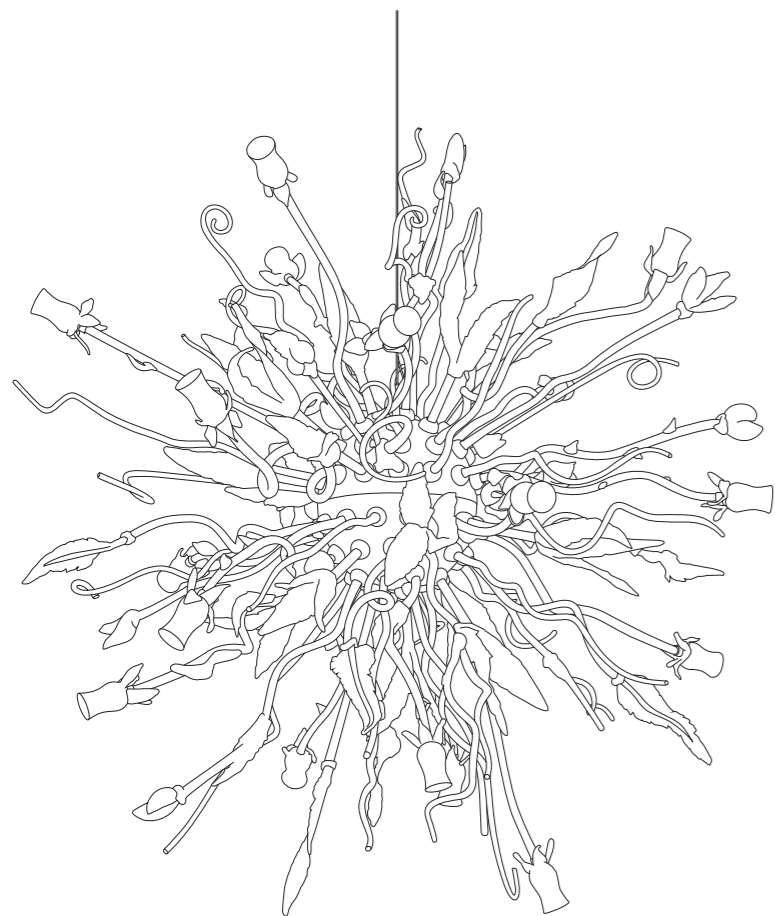

Prato di Fiori

14X049-00 | Dia 2100 mm / Dia 82,68" | artistic hand-blown glass





# PLISSE CLOUD / BY MAURIZIO GALANTE

Maurizio Galante is one of the world's best known haute couture designers and was inspired by the timeless plisse fabric. The primary fashion elements, softness and the typical movement of fabric are transformed here into glass. The smaller object is based on the technique of Plisse, which rotates around its own axis. The impressive larger one is based on layering of multiple levels.

102 / 103

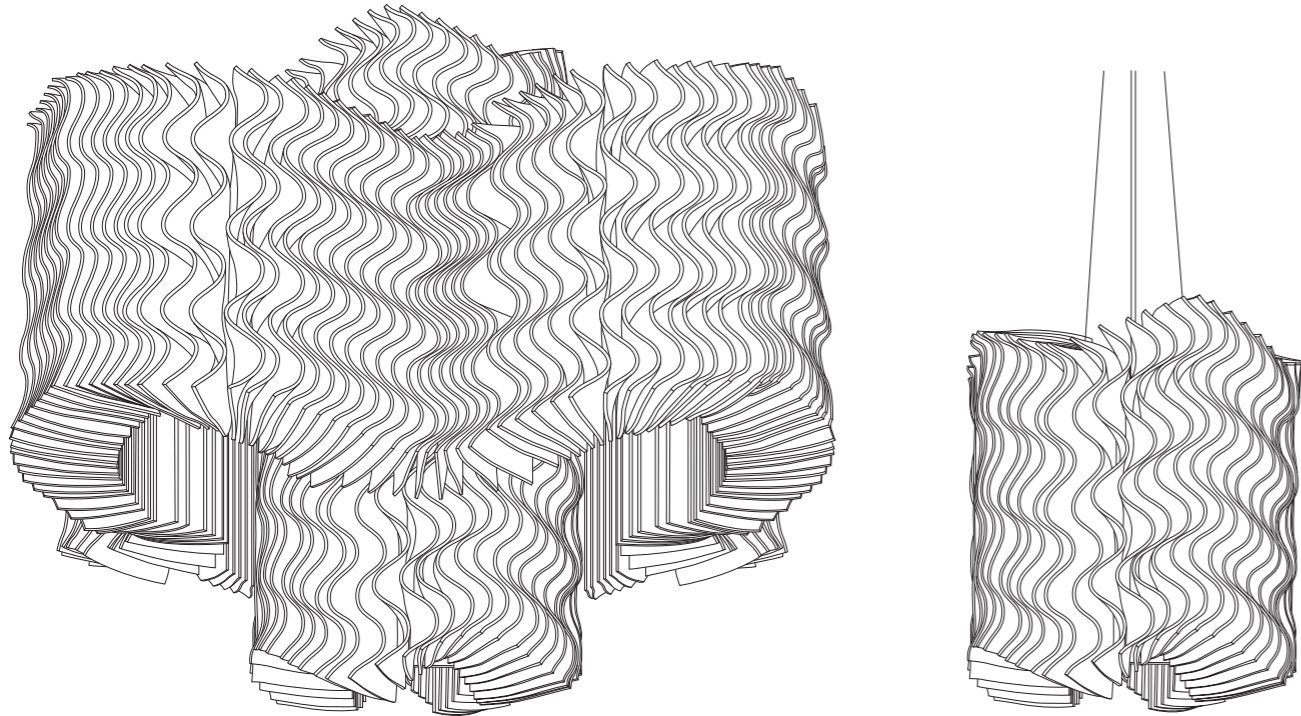

## Plisse Cloud

13X018-00	S	Dia 500×H535 mm + L / Dia 19,69"×H 21,06" + L	artistic fused clear glass
13X025-00	L	Dia 1340×H1035 mm + L / Dia 52,76"×H 40,75" + L	artistic fused clear glass

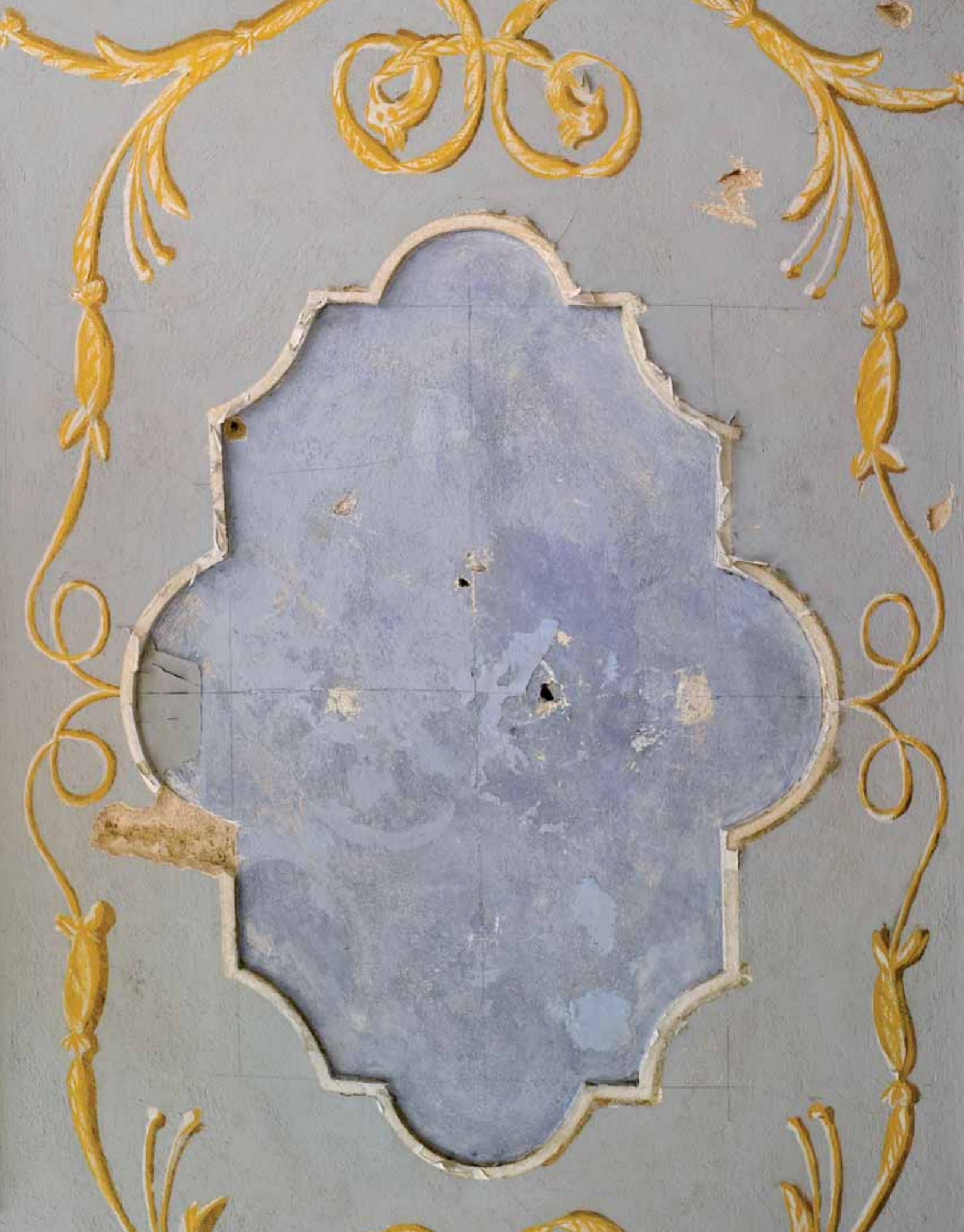

# AND WHY NOT! / BY RENÉ ROUBÍČEK

In an emotionally intense sculptural form, And Why Not resembles a flash. It's an evolution of Roubíček's core designs based on dynamic abstraction. Light glides on large smoothly polished surfaces and, while absorbed by the volume of glass, creates a unique atmosphere.

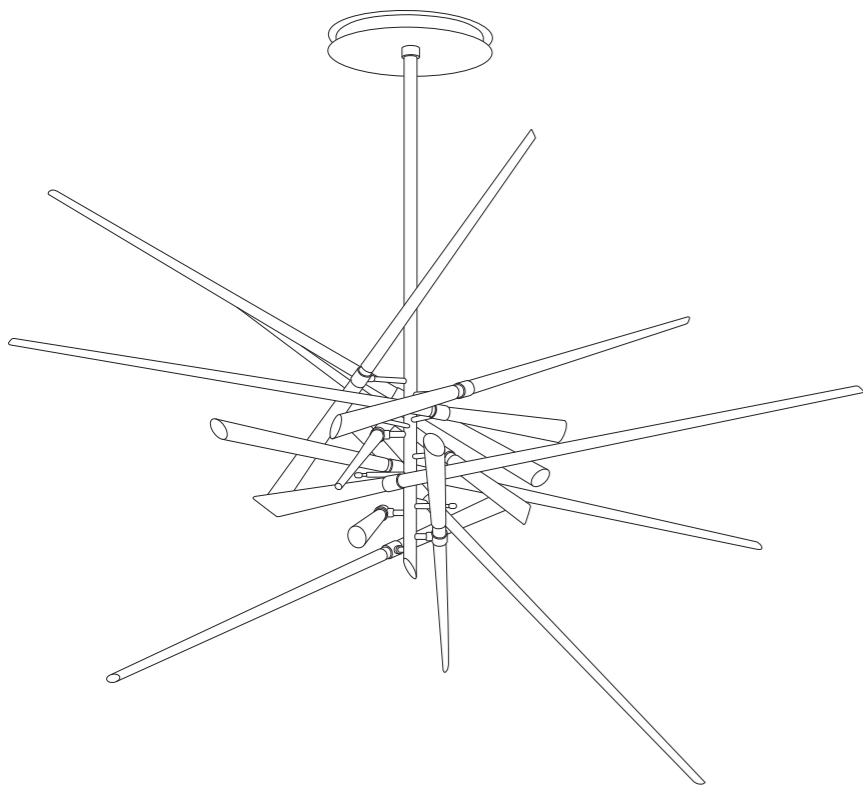

## And Why Not!

13X013-00 | Dia 1200 (max 1500) × OH 1700 mm / Dia 47,24" (max 59,06") × OH 66,93" | clear







# GALAXY LUMINIA / BY BOŘEK ŠÍPEK

With the small Big Bang, history entered a new era that exploded with this extraordinary Šípek chandelier. Apparently disparate decorative components combine into a playful assemblage of forms, materials and stories. Galaxy Luminia resembles a new living species and, until The Big Bang, lives its own independent life.

Quadrix lenitas

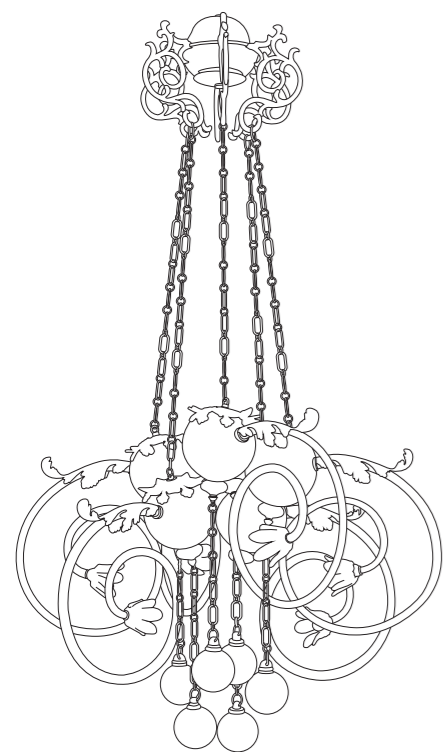

## Galaxy Luminia

13X030-00	Mixia	Dia 1300 × H 1500 mm + L / Dia 51,18" × H 59,06" + L	artistic hand-blown glass
13X031-00	Lumina	Dia 700 × H 1100 mm + L / Dia 27,56" × H 43,31" + L	artistic hand-blown glass
13X032-00	Lenitas	Dia 1200 × H 1500 mm + L / Dia 47,24" × H 59,06" + L	artistic hand-blown glass
13X033-00	Besfix	Dia 1300 × H 1400 mm + L / Dia 51,18" × H 55,12" + L	artistic hand-blown glass
13X034-00	Omnia	Dia 300 × H 1000 mm + L / Dia 11,81" × H 39,37" + L	artistic hand-blown glass





Amoria mixia



Cascadia lumina



# DROPLETS / BY JAN PLECHÁČ & HENRY WIELGUS

Inspired by nature, emotion and a unique frozen moment, this lighting sculpture reminds us of our fascination with water. It captures the perfection of the natural movement when water collects into a drop. The entire composition, as well as the individual elements and their shapes play with the magic of water, air and gravity. The harmonious density gradient highlights this instant, providing sensations of depth and motion.

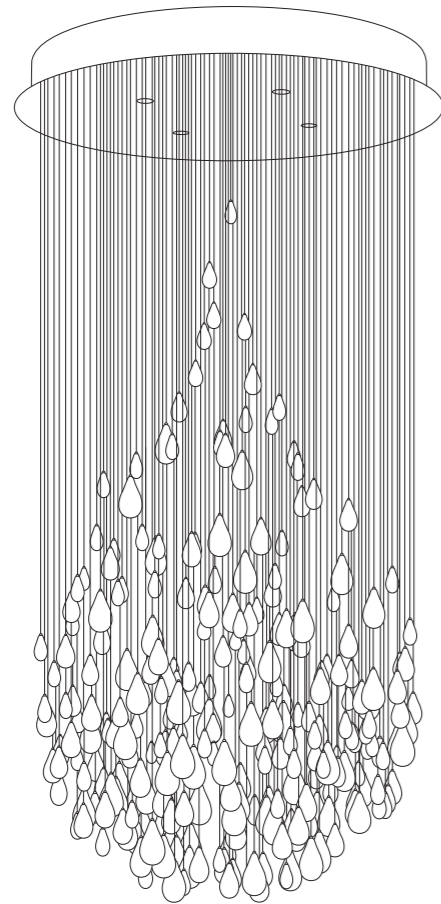

## Droplets

15X016-00	on ceiling silver	Dia 1000 × H 1840 × OH 2570 mm / Dia 39,37" × H 72,44" × OH 101,18"	silver / clear
15X016-01	on ceiling gold	Dia 1000 × H 1840 × OH 2570 mm / Dia 39,37" × H 72,44" × OH 101,18"	gold / clear
15X023-00	on ceiling silver	Dia 1500 × H 2740 × OH 4570 mm / Dia 59,06" × H 107,87" × OH 179,92"	silver / clear
15X023-01	on ceiling gold	Dia 1500 × H 2740 × OH 4570 mm / Dia 59,06" × H 107,87" × OH 179,92"	gold / clear





# UOVO / BY RONY PLESL

Eerily like something from a fairytale, Uovo or 'Eggs' sparkle with mystical radiance from a faraway land. This reflective art-glass lighting sculpture shines like a mountain of precious rounded mirrors, capturing nearby objects and multiplying them to infinity. Uovo's matchless charm and creativity reflects its design in two pieces with exceptional technical expertise. One of these sculptures, Uovo d'argento, is comprised of silver eggs, handcrafted by silvering clear blown-glass components from the inside. The matching piece, Uovo d'oro, features golden eggs, with their coloring achieved by silvering the insides of amber glass components.

120 / 121

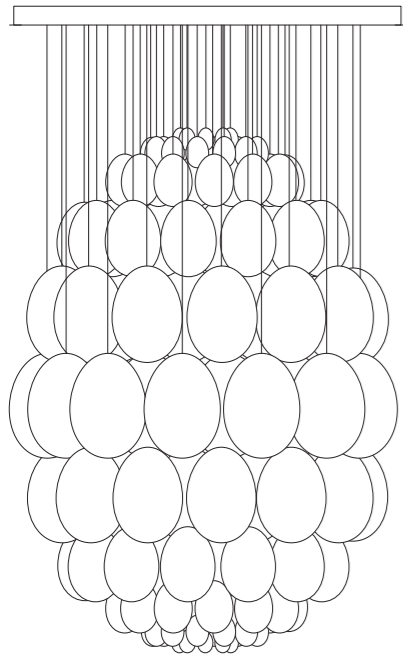

## Uovo

11R002-00	S	Dia 880 × H 1200 × OH 1500 mm / Dia 34,65" × H 47,24" × OH 59,06"	perla nera
11R002-01	S	Dia 880 × H 1200 × OH 1500 mm / Dia 34,65" × H 47,24" × OH 59,06"	smoke
11R002-02	S	Dia 880 × H 1200 × OH 1500 mm / Dia 34,65" × H 47,24" × OH 59,06"	gold
11R002-03	S	Dia 880 × H 1200 × OH 1500 mm / Dia 34,65" × H 47,24" × OH 59,06"	silver
11R001-00	L	Dia 1200 × H 1637 × OH 2100 mm / Dia 47,24" × H 64,45" × OH 82,68"	gold
11R001-01	L	Dia 1200 × H 1637 × OH 2100 mm / Dia 47,24" × H 64,45" × OH 82,68"	silver
11R001-02	L	Dia 1200 × H 1637 × OH 2100 mm / Dia 47,24" × H 64,45" × OH 82,68"	smoke
11R001-03	L	Dia 1200 × H 1637 × OH 2100 mm / Dia 47,24" × H 64,45" × OH 82,68"	perla nera









# GROWING VASES / BY NENDO

Extraordinarily playful and fresh, as never seen before. Such illogical words can be used to describe Growing Vases, yet they still fail to capture its essence. There are no words to express the whimsical nature of this lighting installation. Nendo and Lasvit collaborated to create an art piece that conveys the quixotic appeal of glass as derivative and incomplete, yet provides a breath of fresh air and opens new possibilities. Created in collaboration with Czech Bohemian glass, this lighting installation alludes to a whimsical glass forest populated by abstract flowers and branches. The principle of a flower and a vase here is turned upside down. By turning the pipes into the flowers and branches and blowing the glass into a vase, suddenly the vases bloom with flowers instead of flowers blooming in vases! Growing Vases breaks conventions and symbolizes the birth of life.

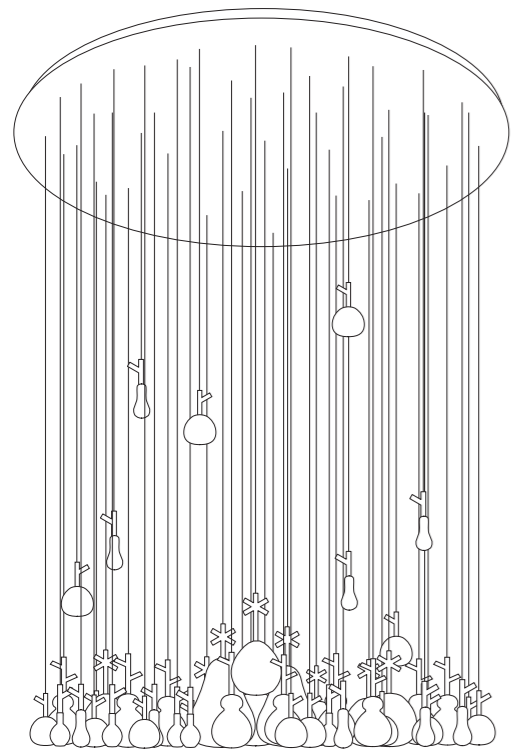

## Growing Vases

11X003-00 | Dia 1000 x 1400 mm / Dia 39,37" x OH 55,12" | clear glass with sandblasting







# LASVIT LIMITED EDITIONS

# HOMUNE / BY MICHAEL YOUNG

A hand-blown table leg and top made of clear crystal. The Lasvit team first developed a specific blowing technology to enable the production of Homune. The leg is conceived as a fractal structure produced by 6 different forms repeated 6 times. Each of the 36 elements was first hand blown and then fashioned into a single piece.

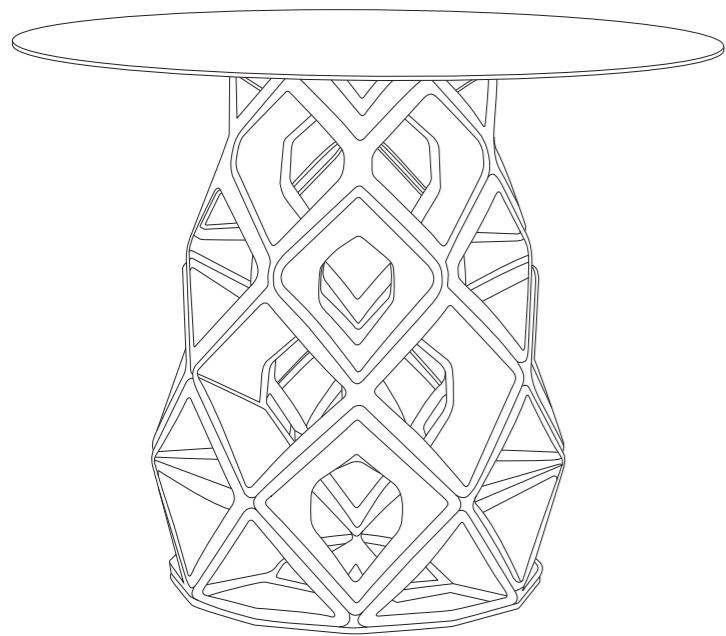

## Homune

12K074-01 | Dia 1200 x H 720 mm / Dia 47,24" x H 28,35" | clear or amber



# PATCHWORK / BY NENDO

The patchwork system of layering, using different kinds of glass cut to complement one another inspired the Patchwork – glass lamp and vase. These pieces combine the fine cut techniques of Bohemian glass with the ancient production method for sheet glass. In this case, a variety of objects, already decorated with traditional cut glass patterns, were reheated, sliced apart and then re-attached to create a single large object.

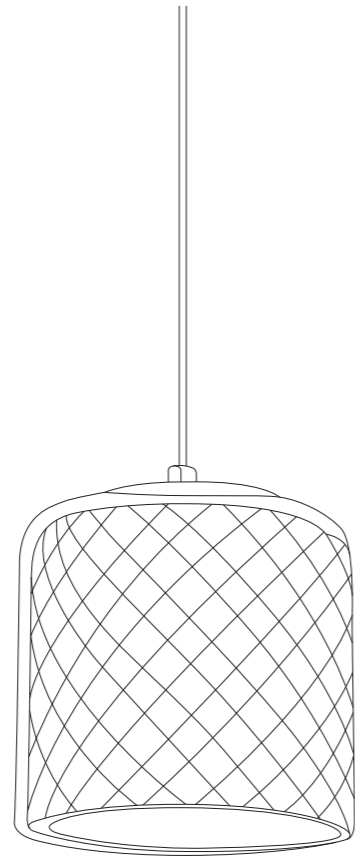

## Patchwork

13X021-00 | pendant | Dia 240 mm x H 240 mm + L / Dia 9,45" x H 9,45" + L | clear artistic hand-blown glass





# OVERFLOW / BY NENDO

This Overflow piece derives from the unique forms created when free-flowing liquid glass hardens in place. Glass masters position plate glass into a frame with a section missing, progressively heating the glass until it becomes molten. They then allow the molten glass to drain from the void in the form. Allowing the glass to harden again, the edge responds to surface tension, creating a table and surface that resembles a pool of water.

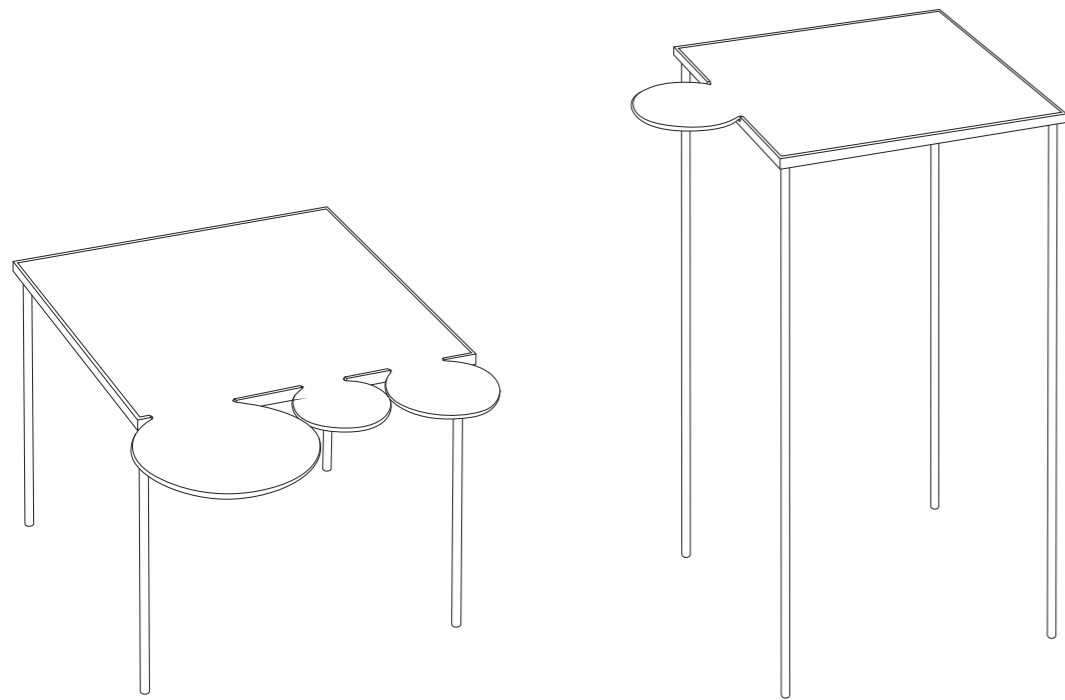

## Overflow

12X011-00 (01)	W 350 x D 460 x H 560 mm / W 13,78" x D 18,11" x H 22,05"	structured glass / white coated metal
12X012-00 (06)	W 490 x D 430 x H 310 mm / W 19,29" x D 16,93" x H 12,20"	structured glass / white coated metal
12X013-00 (08)	W 510 x D 380 x H 310 mm / W 20,08" x D 14,96" x H 12,20"	structured glass / white coated metal
12X014-00 (09)	W 350 x D 350 x H 710 mm / W 13,78" x D 13,78" x H 27,95"	structured glass / white coated metal
12X015-00 (11)	W 485 x D 500 x H 310 mm / W 19,09" x D 19,69" x H 12,20"	structured glass / white coated metal
12X016-00 (12)	W 480 x D 470 x H 560 mm / W 18,90" x D 18,50" x H 22,05"	structured glass / white coated metal



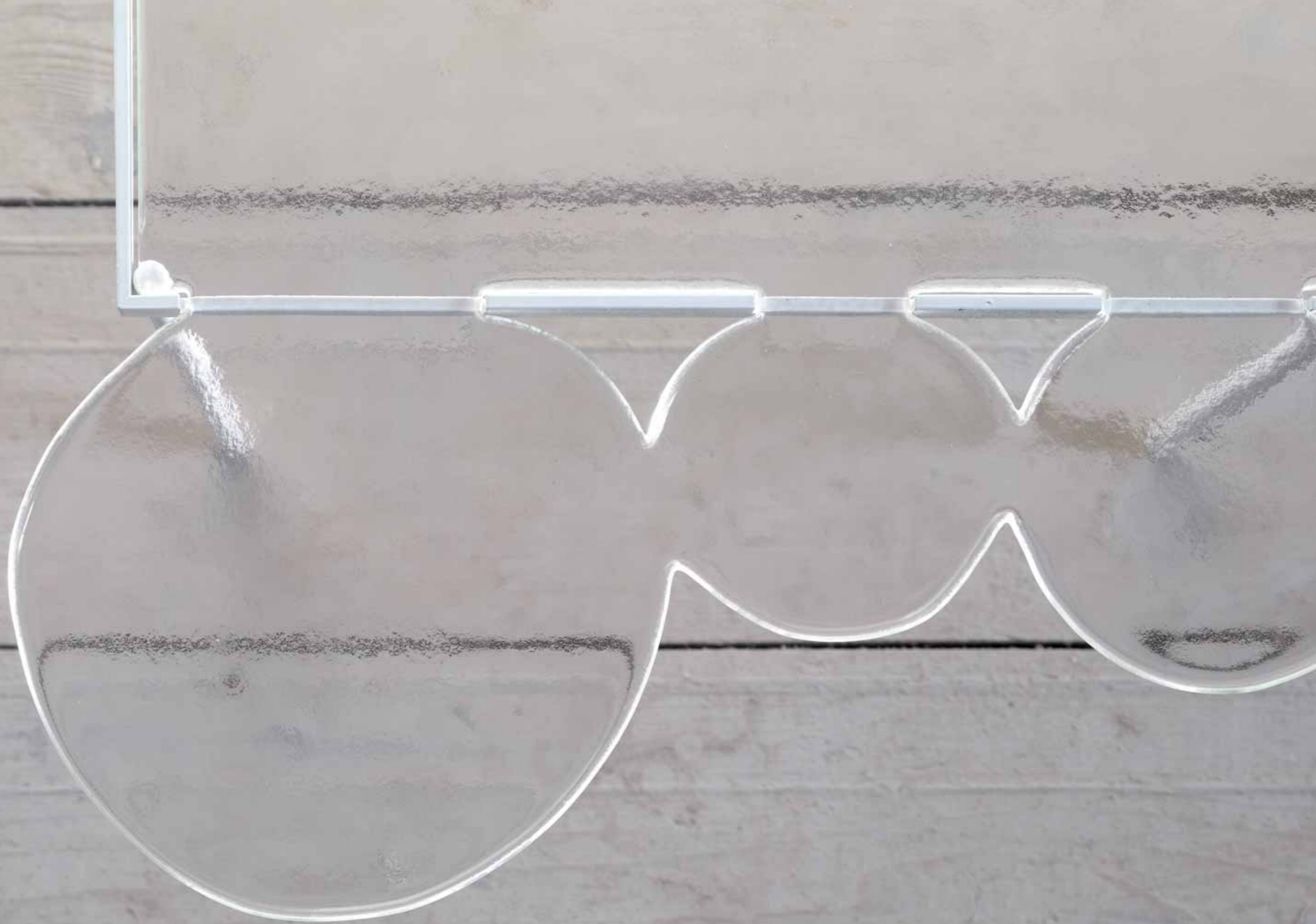

# INNERBLOW / BY NENDO

Innerblow is inspired by the way glassblowers draw a lump of molten glass into the tip of a metal pipe and create a form by expanding the glass with their breath blowing through the metal. The glass masters expand the glass into a square metal form and leave it in place rather than removing it. They then flip the form: the metal mold becomes the table's legs, while the glass becomes its flat top surface. Each table is unique because each piece of hand-blown glass is unique.

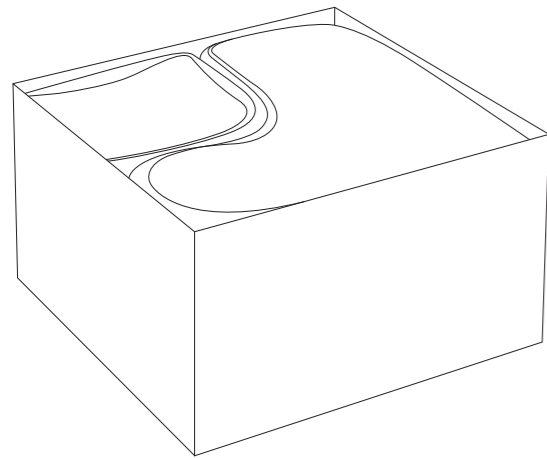

## Innerblow

12X005-02	L 500 × W 500 × H 300 mm / L 19,69" × W 19,69" × H 11,81"	table clear / white coated metal
12X005-04	L 500 × W 500 × H 300 mm / L 19,69" × W 19,69" × H 11,81"	table clear / white coated metal
12X006-00	L 1400 × W 400 × H 300 mm / L 55,12" × W 15,75" × H 11,81"	bench clear / white coated metal
12X004-00	L 1100 × W 1100 × H 300 mm / L 43,31" × W 43,31" × H 11,81"	table clear / white coated metal





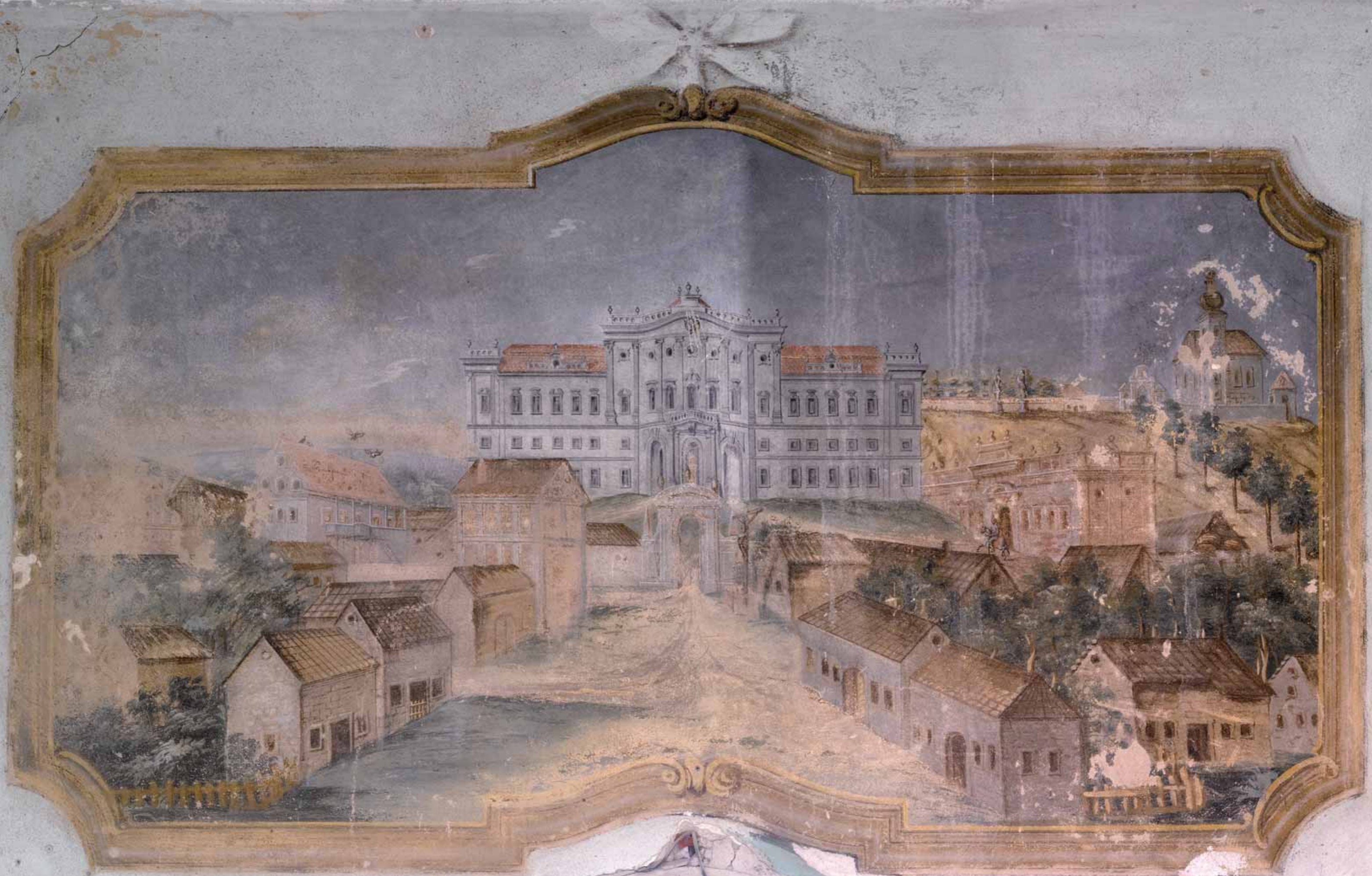

# OUR DESIGNERS



Humberto & Fernando  
Campana



MEJD Studio



Mária Čulenová



Lucie Koldová



deForm



Gabriela Náhlíková



Peter Olah &  
Lars Kemper



Maurizio Galante



Arik Levy



Bořek Šípek



Rony Plesl



Michael Young



Oki Sato (Nendo)



Maarten Baas



René Roubíček



Jan Plecháč &  
Henry Wielgus



Maxim Velčovský

# OUR OFFICES

## Headquarters / Novy Bor / Czech Republic

Lasvit s.r.o.  
namesti Miru 55 / 473 01 Novy Bor / Czech Republic  
T+420 481 120 810 / F+420 481 120 622  
E lasvit@lasvit.com / www.lasvit.com

## Flagship Showroom / Prague

Lasvit s.r.o.  
Komunardu 32 / 170 00 Prague / Czech Republic  
T+420 222 362 990 / F+420 481 120 622  
E lasvit@lasvit.com / www.lasvit.com

## Hong Kong

Lasvit Limited / H.K.  
8F / The Hennessy / 256 Hennessy Road / Wan Chai / Hong Kong S.A.R.  
T+852 2866 1234 / F+852 2866 2212  
E asia@lasvit.com / www.lasvit.com

## Singapore

Lasvit Pte. Ltd. / Singapore  
75 Neil Road / Singapore 088902  
T+65 6542 9422 / F+65 6542 5040  
E singapore@lasvit.com / www.lasvit.com

## Shanghai

Lasvit Co. Ltd. / Shanghai  
Room 906 / 9F / No.1728 / West Nanjing Road / Shanghai / 200040 / China  
T+86 21 6133 1813 / F+86 21 6010 0599  
E shanghai@lasvit.com / www.lasvit.com

## Dubai

Lasvit Middle East FZ-LLC  
P. O. Box 262731 / Dubai Design District / A 109 / Building 6 / Dubai / UAE  
T+971 4453 8689 / F+971 4453 8784  
E me@lasvit.com / www.lasvit.com

## Mumbai

LASVIT Pvt. Ltd. / India  
Regus / Level – 2 / Raheja Centre Point / 294 CST Road / 400098 Mumbai / India  
T+91 99 53 73 53 48  
E india@lasvit.com / www.lasvit.com

## Los Angeles

Lasvit Inc. / USA Headquarters  
28368 Constellation Road Unit 350 / Valencia / California / 91355 USA  
T+1 661 294 6507 / F+1 661 294 6524  
E america@lasvit.com / www.lasvit.com

## New York

Lasvit Inc. / East Coast Area Headquarters / Lasvit, Inc., New York  
51 Wooster street / New York / NY 10013 USA  
T+1 212 219 3043 / F+1 212 219 3053  
E america@lasvit.com / www.lasvit.com

## London

Lasvit Limited / UK  
7 Tilney Court / Old Street / London EC1V 9BQ / United Kindgdom  
T+44 20 7490 2004  
E uk@lasvit.com / www.lasvit.com

## Milan

Lasvit / Italy  
via Gaspare Bugatti 15 / 20144 Milano / Italy  
T+39 02 58108589 / F+39 0287163002  
E italy@lasvit.com / www.lasvit.com

## Paris

Lasvit / France  
10 rue Saint-Augustin / 75002 Paris / France  
T+33 (0) 7 50 90 78 04  
E france@lasvit.com / www.lasvit.com

## Moscow

Lasvit / Russia  
2 Tverskaya-Yamskaya Str. 31135 / office 612 / Moscow 125047 / Russian Federation  
T+7 965 2166716  
E russia@lasvit.com / www.lasvit.com

## Astana

Lasvit / Kazakhstan  
Kunaev street 12/1 / office 115 / Astana 010000 / Republic of Kazakhstan  
T +7 776 774 9669  
E kazakhstan@lasvit.com / www.lasvit.com

First published and distributed by

Lasvit s.r.o.  
nám. Míru 55 / Nový Bor / 473 01 / Czech Republic  
T +420 481 120 810 / F +420 481 120 622  
E lasvit@lasvit.com / www.lasvit.com

Edited and produced by Lasvit s.r.o.

Book Design – Symbiont  
Typeface – Lasvit / Kievit  
Photo – Filip Šlapal

© Lasvit 2015

All rights reserved. This publication or its parts may not be reproduced, stored or shared in any form, including texts and photos without permission in writing from the copyright owner(s).

Printed and bound in the Czech Republic / Indigoprint s.r.o.